

AQUASURE

PREMIER SERIES
DRINKING WATER SYSTEM



AQUASURE

OWNER'S MANUAL

⚠ IMPORTANT!

For optimum performance and protection against contaminants, please fully read this owner's manual before proceeding with installation.

WELCOME & CONGRATULATIONS

Thank you for choosing Aquasure. This owner's manual will guide you through the necessary steps to fully self-install the Premier Reverse Osmosis system.

For MAXIMUM effectiveness please thoroughly read this manual.

This owner's manual serves as a source of general guidance; nevertheless, it is crucial to emphasize that errors during installation may result in system malfunction and can potentially void the warranty. Therefore, it is strongly recommended to engage the services of a licensed plumber for professional installation. In the event that you need support, our Aquasure technicians are available to answer any questions during hours of operation as listed below.

Hours of Operation: M-F 8:30AM - 5:30PM PST

Telephone: 1800-661-0680

Email: support@aquasureusa.com

Online Chat: aquasureusa.com/support

SUBSCRIBE AND SAVE

Never worry again when it's time to replace your filters.

Save time and money when replacing your Premier Reverse Osmosis filters with our Subscribe and Save program!

Get 25% off your first order and then 10% each order after that.

Signing up is easy...

1. Scan the QR code on the right OR go to aquasureusa.com/subscribeandsave
2. Select your replacement filters
3. Choose when you want to receive your new filters

That's it!

Cancel or change your delivery frequency at any time.

SCAN ME



TABLE OF CONTENTS

2	INSPECTION & PREPARATION
2	Be Familiar with the System Before Installation
4	System Operation Parameters and Installation checklist
5	Feed Water Adapter with 3/8" or 1/2" Connection Setup
6	Quick Connect / Compression Fitting Installation Instruction
7	Drinking Water Faucet Mounting Hole Preparation
10	INSTALLING THE SYSTEM
10	STEP 1. Feed Water Adapter Installation
12	STEP 2. Drain Saddle Installation
13	STEP 3. Tank Ball Valve Installation
13	STEP 4. Drinking Water Faucet Installation
14	STEP 5. Mounting or Placement of the System
15	STEP 5 for AS-PR100E Models
16	STEP 6. Connecting the System
17	STEP 7. System Startup
18	SYSTEM MAINTENANCE
18	Filter Replacement Time Frame
18	Removing the FLOWLOK™ Tray
19	Replacing Stage 1 & 2 Pre-Filters
20	Replacing Stage 3 & 4 RO membrane and Post Carbon Filter
22	SYSTEM TROUBLESHOOTING
26	LIMITED PRODUCT WARRANTY



Need support? Visit our support hub at aquasureusa.com/support

WELCOME

Thank you for choosing Aquasure. Before you start using your Aquasure drinking water system, take a few minutes to become familiar with the basics.

Filter replacement

Be sure to change your Aquasure water filters according to the recommended filter replacement schedule. This helps keep your Aquasure drinking water system running in top condition. See page 18

Register your system within 60 days and extend your warranty for an additional two years of coverage

Help expedite any support needed and also receive additional 2 years of limited warranty by registering your system online at <http://www.aquasureusa.com/warranty-registration>

INSPECTION & PREPARATION

I. Get Familiar with the System Before Installation



IMPORTANT! Please read the entire manual and become familiar with instructions and parts needed before proceeding with the installation. Hiring a professional plumber who will adhere to all local, state and federal guidelines is recommended for a proper installation.

Inspect the System

Please take the system and all the components out of the box. Inspect the system and all the connection fittings carefully, make sure nothing is damaged during shipping. If any part is cracked or broken, please do not proceed with the installation and contact Aquasure or your distributor for an exchange or diagnosis.

System Components Breakdown (See Dia A)

1. System Cover
2. System Head
3. Stage 1 Sediment Filter
4. Stage 2 Carbon Block Filter
5. Stage 3 Reverse Osmosis Membrane
6. Stage 4 Post Filter
7. Pressurized Water Storage Tank
8. Faucet
9. Flowlok Safety Tray
10. Flowlok Leak Detector
11. ShokBlok Pressure Protection Valve
12. Tank Ball Valve
13. Feed Water Adapter
14. Flow Restrictor
15. Faucet Adapter
16. Color-Coded Tubing
17. Drain Saddle Valve
18. Teflon Tape

Recommended Tool List for System Installation

- Cordless Drill
- Carbide Grinding Burr
- 1/4" (6mm) Drill Bit
- 7/16" (11mm) Drill Bit
- 1/2" (13mm) and 5/8" (16mm) open-end wrenches (or adjustable)
- Philips screwdriver
- Flashlight or Drop Light
- Protective eye wear (i.e. goggles)

Dia. A



II. System Operation Parameters and Installation checklist



IMPORTANT! The following conditions for the feed water supply must be met or warranty will be void and manufacturer assumes no responsibility for damage to system or property.

1. Water Temperature Parameters

- Maximum: 105° F (40.6° C)
- Minimum: 33° F (0.55° C)



WARNING: Do not allow the system to freeze, the membrane always contains water and will be destroyed if frozen. Do not plumb system to hot water, The tubing will expand or burst, and membrane will be destroyed which will void warranty and manufacturer's responsibility.

2. Water Pressure Parameters

- Maximum: 75 PSI (5.27 kg/cm²)
- Minimum: 40 PSI (2.81 kg/cm²) / 0 PSI for system equipped with electric pump.



WARNING: This system is designed to operate at a water pressure in the range of 40 PSI to 75 PSI (2.81 kg/cm² to 5.27 kg/cm²). Operating at a pressure lower than the minimum required PSI will result in lower quality and quantity of product water. Operating at a pressure higher than the maximum allowed PSI will cause severe damage to the system.



WARNING: Do not proceed with the installation until water pressure is confirmed to be lower than 75 psi. A pressure regulator must be installed on the feed water source coming into the home to reduce water pressure going into the system and ensuring water pressure does not exceeds 75 psi.

3. Water Condition Parameters

- Turbidity: <5 NTU
- pH: 4 - 11
- Hardness: < 7 grains per gallon (< 120 ppm)
- Sulfide, Iron Manganese: < 0.01 ppm
- Chlorine: < 2 ppm
- Total Dissolved Solids (TDS): < 1,000 ppm



WARNING: If the hardness of your water is above 10 gpg (171mg/L), lime scale will build up rapidly on the membrane. Scale buildup will plug the membrane and make the system ineffective. We do not recommend this reverse osmosis systems be used with water in excess of 10 gpg (171 mg/L) hardness unless the water is softened prior to the reverse osmosis system.

4. Pre-install environment checklist

- Installation needs to comply with state and local laws and regulations.
- System must be installed indoor away from possible environmental damage
- Do not use with water that is microbiologically unsafe or of unknown quality without adequate disinfection before or after the system. Systems certified for cyst reduction may be used on disinfected water that may contain filterable cysts.
- The system is best installed under the kitchen sink. But if that is not feasible, you can install the system anywhere where there is a cold water supply with sufficient water pressure, and an outlet to drain off the rinse water from the system.

5. System Dimensions & Specifications

IMPORTANT! Please make sure there is sufficient space for the system to be installed properly. It is best to first place the system in the space to see if there is room for the system to be mounted and installed properly. Do not install the system in an area where it is exposed to extreme hot and/or cold weather or under direct sunlight.

WARNING: It is recommended to mount the system on the wall with the correct screws appropriate for the mounting location. If mounting the system is not an option, please make sure system is installed in a space with secure footing. Improper placement of the system may cause the system to tip over and break due to the added weight of the water.

- System Dimensions: 15" w x 5.25" d x 15" h
- System Weight: 8 lbs (3.6kg)
- Tank Dimensions (with Valve): 11.3" d x 16.75" h
- Tank Capacity: 1.9 - 3.2 gal. (7.2 - 12.1L)
- Tank Weight: 6.6 lbs (Empty) / 40 lbs (Full - Varies by water pressure)

III. Feed Water Adapter with 3/8" and 1/2" Connection Setup

Note: The feed water adapter is setup to work with either 3/8" or 1/2" cold water line. Please make sure the o-ring is properly placed before installation.

1. Converting 3/8" connection to 1/2" (See Diagram B)

- Install the 3/8" to 1/2" outlet converter to the adapter by rotating clockwise until tightened.
- Install the 3/8" to 1/2" inlet converter to the adapter by rotating counter-clockwise until tightened.

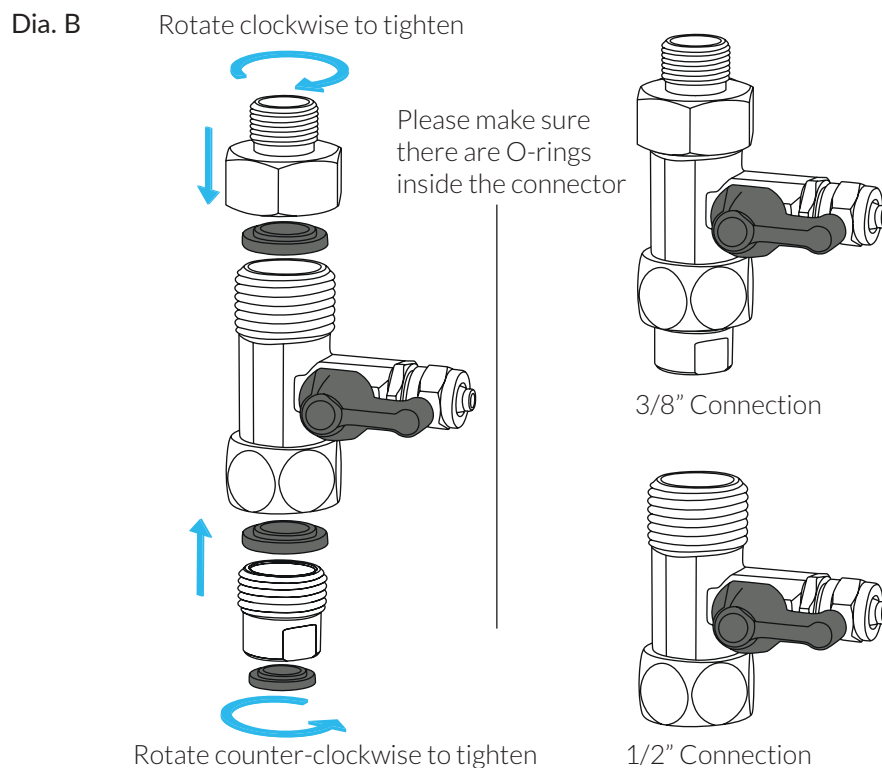

IV. Quick Connect / Compression Fitting Installation Instruction

Note: This systems is equipped with quick connect fittings. These user-friendly fittings provide superior performance and leak-free seal if installed correctly.

1. Quick Connect Tubing Installation

- Inspect Tubing (See Diagram C-1) - The system comes with pre-cut tubing that is cut cleanly and squarely to ensure proper connection. Please ensure that the tube has a smooth outside diameter without any burrs, chamfers or score marks prior to inserting it into the fitting. Tubing that has not been cut properly can cause drips and leaks
- Insert Tubing (See Diagram C-2) - Push the tubing through the collet and o-rings until it bottoms out against the tube stop. The collet holds the tube in place and the O-ring provides a leak resistant seal. If you need to remove the tubing always re-cut before connecting tubing again. Scores on tubing can cause failure.
- Push and pull the tubing toward and away from the fitting to ensure that is installed properly. (See Diagram C-3)

Dia. C-1



Dia. C-2

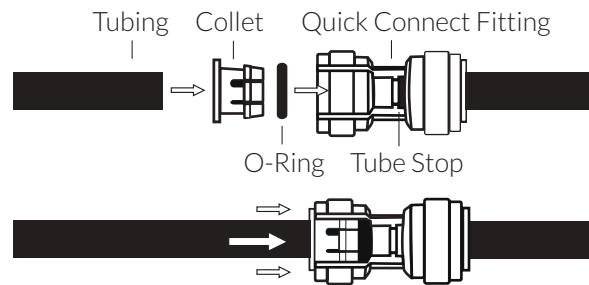

Dia. C-3

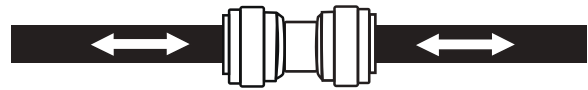

2. Quick Connect Tubing Removal

- Release the Tubing (See Diagram B-4)
 - Relieve pressure from the tubing and fitting. Push the collet flange against the fitting body while pulling the tubing away from the fitting to release it.

Dia. C-4

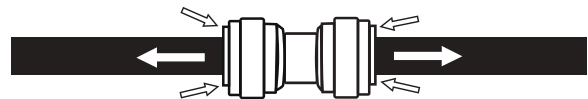

IMPORTANT! Should a leak occur at a fitting, the cause is generally defectively cut tubing. To fix a leak, relieve pressure, release tubing, cut o at least 1/4" from the end (square cut), reattach the tubing and confirm the connection is leak free. Each time a new connection is made, it is advisable to cut off 1/4" from the end of the tubing using these fittings.

3. Optional Compression Nut Fitting (See Diagram B-5)

- Slip the compression nut onto the tubing.
- Slide the plastic sleeve onto the tubing
- Place the insert inside the tubing
- Slide the compression nut up and tighten it onto the flange using a wrench.

Dia. C-5

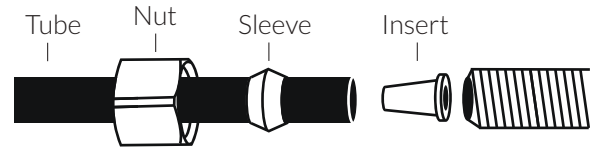

V. Drinking Water Faucet Mounting Hole Preparation

IMPORTANT! Extreme care must be taken in drilling the hole for the dispensing faucet. The surface material of most sinks is extremely hard and brittle and can be easily chipped or cracked. If you are uncomfortable performing the following procedure it is recommended that an experienced plumber is consulted for techniques, installation or other assistance. The system's manufacturer accepts no responsibility for sink top damage resulting from system installation. Before grinding or drilling put on appropriate eye protection (i.e. goggles) to protect yourself from porcelain or metal chips. **EXTREME CAUTION SHOULD BE TAKEN WITH GRANITE, MARBLE AND LIKE MATERIAL.**

WARNING: Many homes are electrically grounded through the plumbing. To protect yourself from serious injury or fatal shock, use a battery-powered hand drill only to make the hole. **DO NOT USE AN ELECTRIC DRILL.**

1. Using an Existing Hole

- Spare Hole: If there is a spare hole covered by a rubber or chrome cover, simply remove the cover and install the drinking water faucet at the location.
- Spray Hose: If the spray hose is not in use, remove the hose and mount the drinking water faucet at the location. Remember to plug up the outlet under the main faucet. If the spray hose uses a diverter at the base of the spout, be sure to remove it to avoid trouble later on.
- Hanging faucet: If drilling a hole is not feasible (i.e. rental home, drill tool not available etc.), the faucet can be placed inside the sink cabinet or wherever convenient without mounting.

2. Pre-drilling preparation

- Check under the sink in the area that you plan to install the faucet and make sure that there is ample of room to secure the mounting hardware. A space of approximately 2 inches in diameter is needed.
- REMOVE EVERYTHING FROM INSIDE THE SINK AND SURROUNDING AREA. Place paper towels in the sink to catch the shavings from the grinding and drilling.
- REMOVE EVERYTHING FROM UNDER THE SINK. Place newspaper or paper towels directly under drilling location in order to catch the drill shavings.

3. Drilling Porcelain or Enamel

WARNING: Metal shavings can oxidize and discolor porcelain. Be extremely careful to cover porcelain sinks. Always wear gloves and protective eyewear when drilling.

- Using a cordless drill with a carbide grinding burr, gently grind away enough porcelain or enamel to more than accommodate the 7/16" (11 mm) drill bit. Approximately the size of a dime. Enough surface material must be removed to expose the base metal.
- Using the 1/4" (6 mm) drill bit, drill a centering or pilot hole in the center of the desired faucet location. It will make it easier for the 7/16" (11 mm) drill bit to cut through the sink
- Switch to 7/16" (11 mm) drill bit and operate the drill slowly and carefully— Especially when the drill bit is about to penetrate the metal. Otherwise, damage to sink may occur. Use lubricating oil to keep the drill bit cool while drilling.

4. Drilling Stainless Steel

- Use a hole punch and hammer to mark the location of where you want to install the faucet. Keep your taps short and control until a dent is visible, this will help keep your drill bit seated when start drilling.
- Apply lubricant to the drill area as drilling at high speed will create a lot of heat which can cause the metal to warp or burn.
- Using the 1/4" (6mm) drill bit, at half speed to drill the hole. This would help prevent it from overheating.
- Switch to 7/16" (11 mm) drill bit and do the same to widen the hole.
- Once the hole is drilled, use the file to smooth out the edges and wipe away the shaving.
- Clean The Area
- Discard paper towels and newspaper used in the sink and below sink. Be very careful not to drop any shavings in the sink or on the floor as they will oxidize and stain surfaces very quickly.

INSTALLING THE SYSTEM



WARNING! Do not proceed with the installation until you have gone over the **System Operation Parameters and Installation Checklist** section on **page 4** of this owners manual and comply with all the conditions listed in that section. Failure to comply may result in property damage and your system warranty will be voided due to non-compliance with the operation parameters.



IMPORTANT! Locate and test the main water supply valve to the house before installing the system. If the main water supply valve fails to shut off the water completely during the test, we recommend contacting your local plumber to fixed the valve before begin installing the system.



Scan QR Code Here to get support Faster! Feel free to contact our support at 1-800-661-0680 during our normal business hour of Monday - Friday from 8:30 am to 5:30 pm PDT. You can also email us at support@aquasureusa.com or visit us on the web at <http://www.aquasureusa.com/support> for installation assistant or support.

STEP 1. Feed Water Adapter Installation

Locating the Cold Water Supply Valve:

1. Locate the Cold water supply valve under the kitchen sink. Turn off the incoming cold water completely by turning the shut-off handle clockwise.
2. Test to see if the cold water line is completely shut off by turning on the faucet in the cold water position. If cold water cannot be turned off, the main water supply to the house must be shut off for the installation.

Connecting with Flex Line Riser: (See Diagram D-1)

1. Loosen the nut and separate cold water riser tube from faucet shank. Gently bent riser tube so that the feed water adapter fits onto the faucet shank.
2. Attached the feed water adapter to cold water supply valve.
3. Attached the cold water riser to the other side of the feed water adapter. (If necessary, apply 3 to 5 rounds of Teflon tape onto the feed water adapter before attaching the cold water riser.)

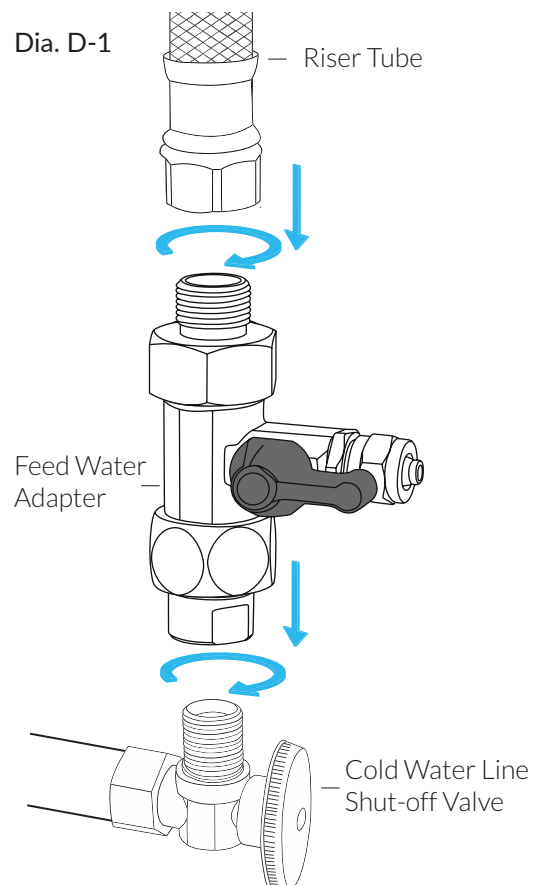

Test For Leaks:

1. Make sure the feed water adapter is in the shut-off position, perpendicular to the feed connection (See Diagram D-2)
2. Turn on the cold water supply to the sink faucet.
3. Check for leaks

Note: If there's a water leak, check the connection and apply more Teflon or tighten the connection more to stop the leak.

Dia. D-2

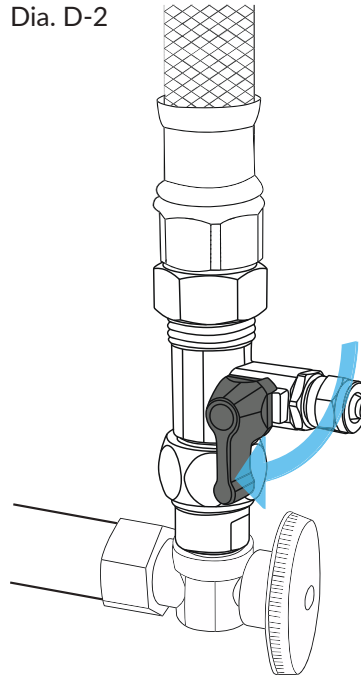

Optional connection for connecting on Solid Copper Riser with Self-Piercer (Sold Separately): (See Diagram D-3)

1. Firmly clamp the self-piercer onto the riser tube by adjusting and tightening the lock nut

CAUTION! Do not overtightened! This will crush and damage the copper riser.

2. Pierce the line by simply screw the T-handle valve clockwise until it stops.

Note: If the hole in the copper tube is not adequately pierced, this may prevent sufficient cold water supply to flow to the system and reduce the system performance. In this event, open and close the self-piercing valve several times to ensure an adequate pierced tube.

Dia. D-3

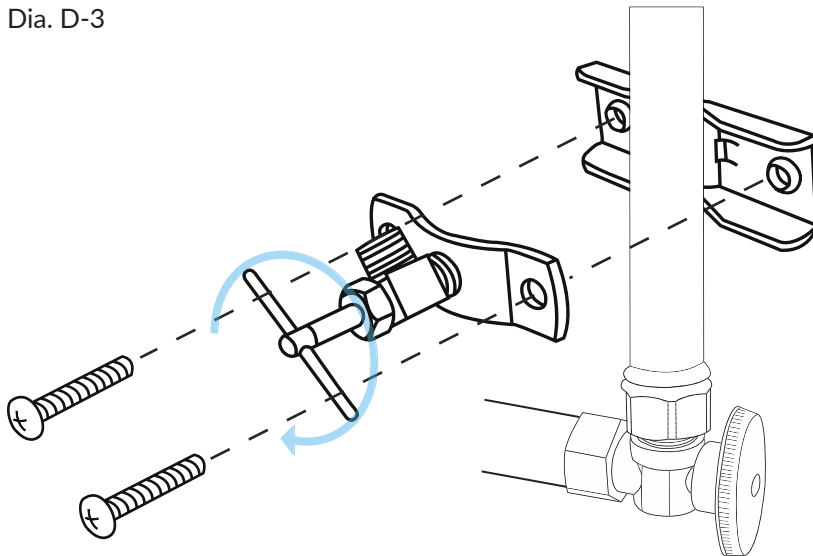

STEP 2. Drain Saddle Installation

1. Locate the optimal placement on the drain pipe to install the drain saddle. (See Diagram E-1)

Note: The drain saddle should be installed above the trap and on the vertical or horizontal tail piece. To reduce potential drainage noise, it is ideal to mount the drain saddle as low as possible on the vertical pipe above the trap or on the horizontal tail piece. If the drain saddle is to be installed on the horizontal tail piece, it is recommended to install the drain saddle where the drain tube connection is on top of the horizontal pipe.

2. Mark the position of the hole on the drain pipe and drill a $\frac{1}{4}$ " hole through one side of the drain pipe. (See Diagram E-2)

Dia. E-1

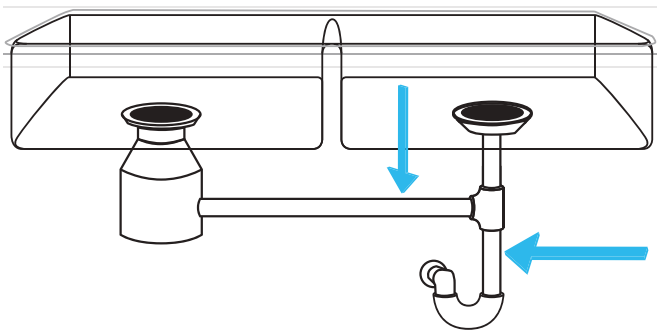

Dia. E-2

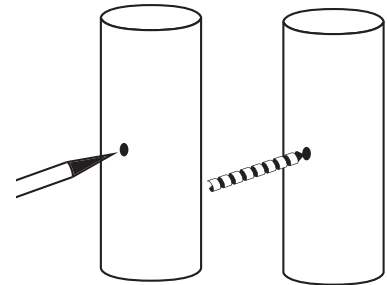

3. There is a piece of self-adhesive sponge gasket provided. Glue this sponge gasket to the inside of the saddle, this will cushion any gap between the saddle and the pipe. Make sure the hole on the sponge is thoroughly punched out and is aligned with the hole on the saddle.

Note: Make sure to align the drain saddle hole to the drilled hole perfectly. Mis-aligning these two holes will block the rinse water and damage the membrane.

4. Attached the drain saddle to the pipe by gently tighten the two screws evenly on both sides of the clamp until the clamp is snug on the pipe. (See Diagram E-3)

CAUTION! Do not over tighten! Over tightening may cause the drain saddle to break or crush the drain pipe.

Dia. E-3

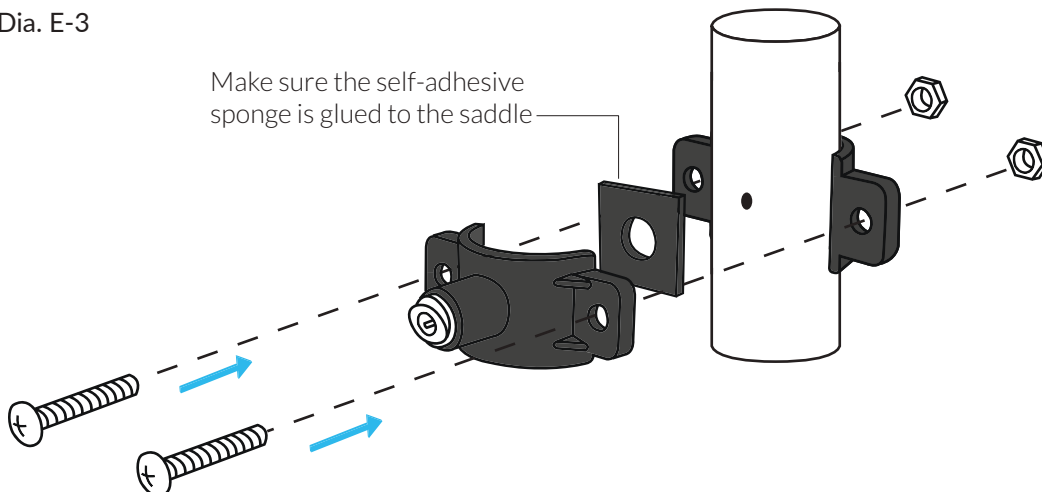

STEP 3. Tank Ball Valve Installation (See Diagram F-1)

1. Attached the tank ball valve on top of the tank.

CAUTION! Do Not over tighten the adapter to avoid breaking and leak.

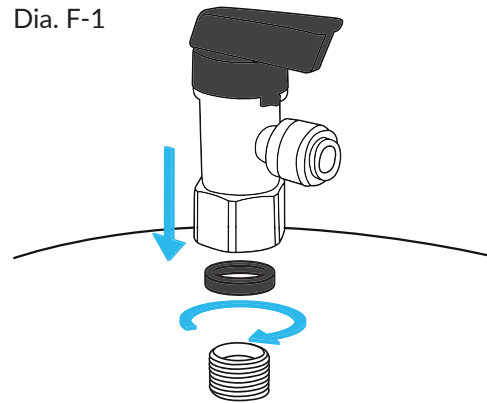

STEP 4. Drinking Water Faucet Installation (See Diagram G-1)

1. Place the faucet base over the drilled hole and make sure the hole is completely covered by the faucet base.
2. Insert the faucet shank through the faucet base and drilled hole completely.
3. From under the sink slip the large, black washer over the faucet shank. Next, slip the lock washer over the faucet shank followed by the thin chrome nut.
4. While holding the faucet assembly above the sink tighten the chrome nut below the sink with an adjustable wrench. Tighten the chrome nut until the faucet assembly does not move. (A faucet wrench is recommended if the space for proper mounting is very limited)

CAUTION! Do Not over tighten the adapter to avoid breaking and leak.

5. Attached the faucet adapter to the shank.

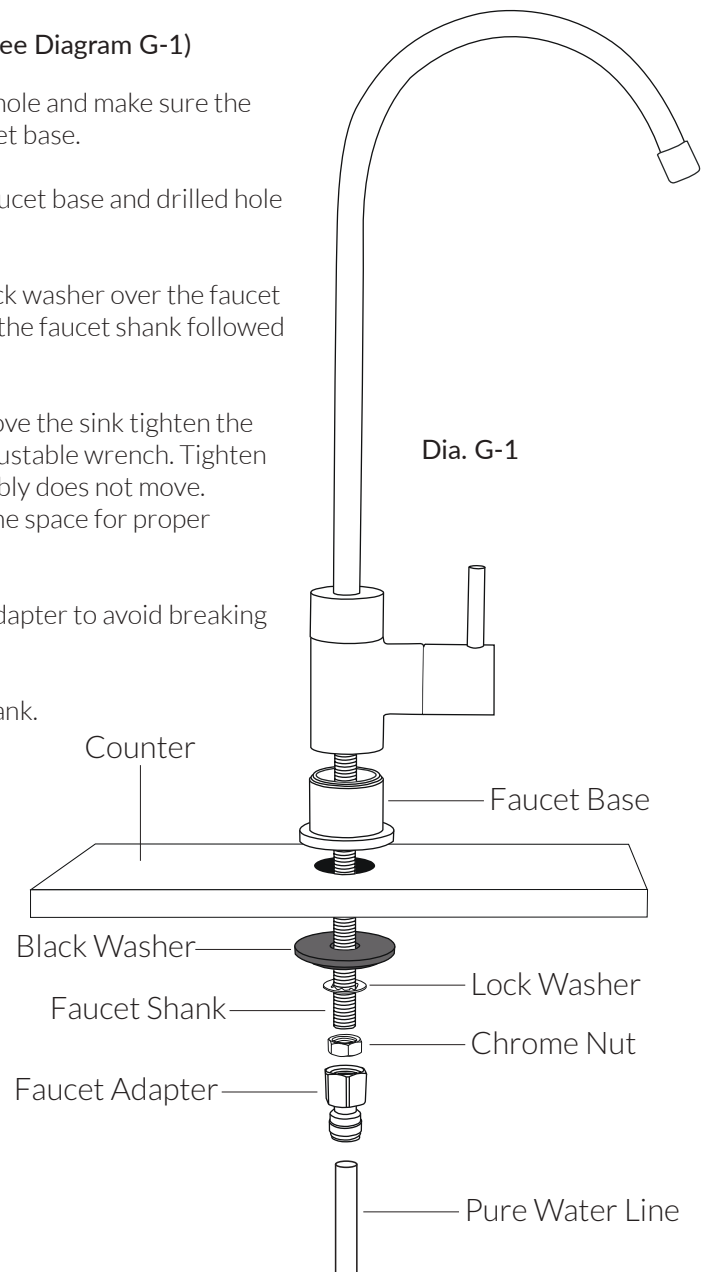

STEP 5. Mounting or Placement of the System



WARNING! If mounting the system is not an option, please make sure system is installed in a space with secure footing. Improper placement of the system may cause the system to tip over and break due to the added weight of the water.

1. Position the system on the wall at the desired mounting location 3 - 4 inches from the cabinet floor to the base of the system. (See Diagram H-1)



IMPORTANT! Be careful not to kink any of tubing on the system as kinked tubing can rupture and leak.

2. Using a pencil or marker and mark the mounting hole on the back of the bracket onto the wall.

Note: Please make sure the bracket mount is leveled using a level tool to ensure evenly distributed stress on the bracket.

3. Set the system aside.
4. Screw the two screws into the wall at the marked position and make sure there is some protrusion space for the bracket to seat securely.
5. Mount the system onto the screw.

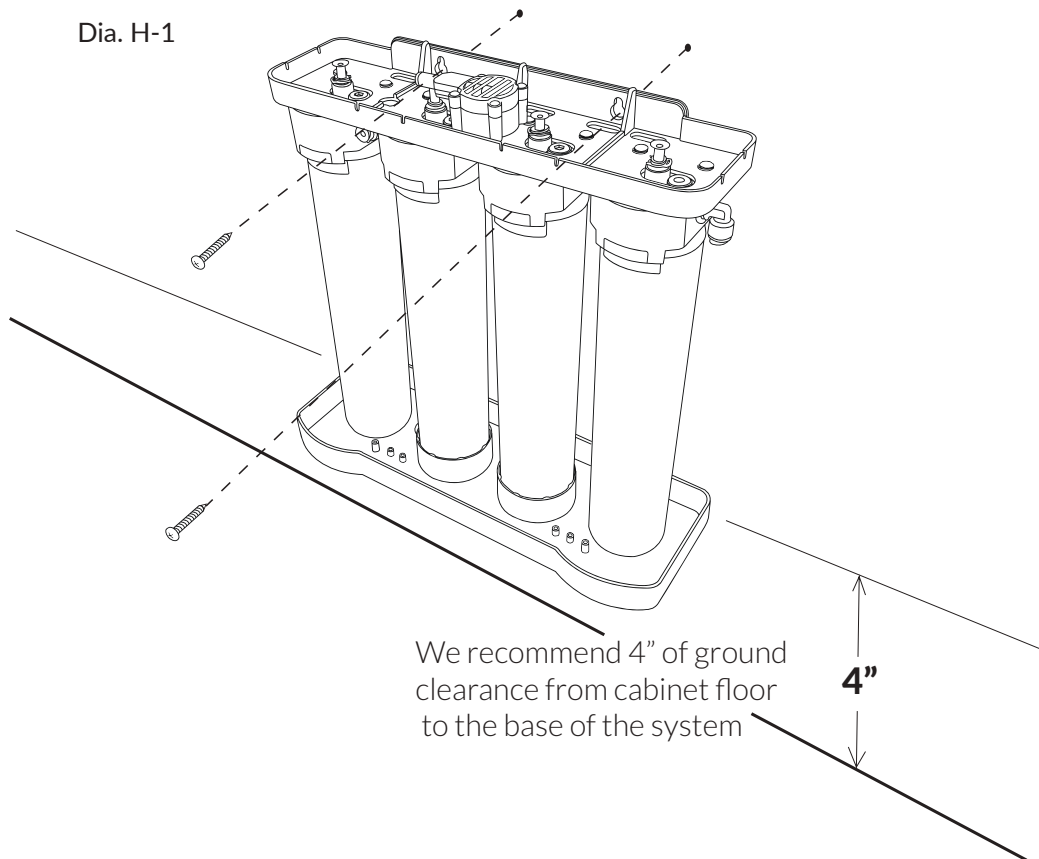

STEP 5. For AS-PR-100E Premier with Electric Pump Models only.

NOTE Please follow the installation manual included with the system until reaching Step 5 of System installation on page 14. Do not follow the Step 5 instruction as the system is no longer wall mountable and require a flat surface area to place the system. Follow the below instruction on connecting the pump to the system.



1. Mount the pump bracket to the system with the provided nuts and bolts.

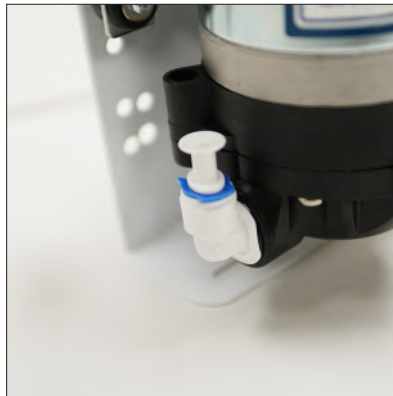

2. Remove the stopper on both sides of the pump.

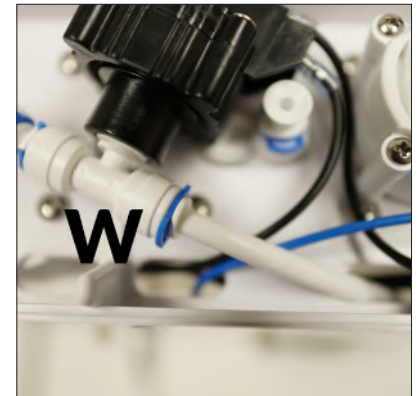

3. Connect the WHITE color-coded tubing from the system (W) to the inlet of the pump (X)

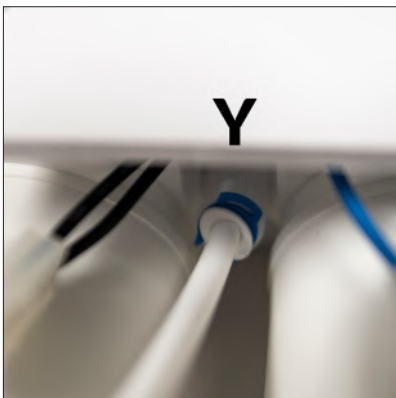

4. Connect the WHITE color-coded tubing from the connection (Y) in between 1st stage AF-PR1 and 2nd stage AF-PR2 to the outlet of the pump (Z)



5. Connect the Male connector from the system colored (Black/Blue) to the Female connector from the pump colored (Black/Red).



6. Connect the Male connector from the power supply colored (Black/Red) to the Female connector from the pump colored (Black/Black)

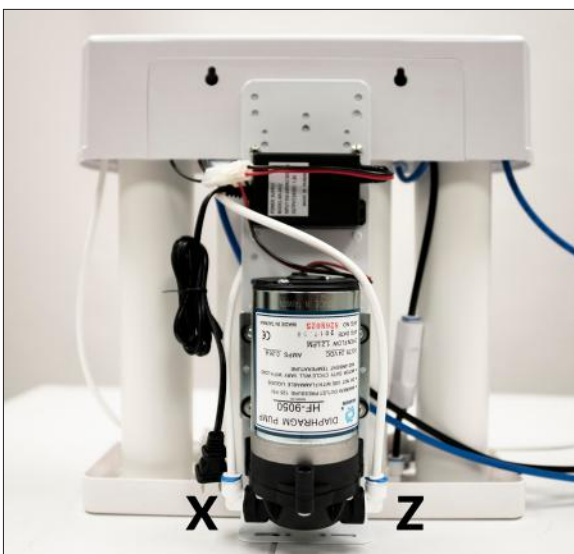

7. Follow STEP 6 of the Owner's Manual to properly connect the system.

8. Follow STEP 7 of the Owner's Manual from 1 to 3 and connect the power supply to the electrical outlet nearby to turn on the pump.

9. Finish up STEP 7 of the Owner's Manual to complete system installation.

STEP 6. Connecting the System (See Diagram I-1)

Note: Remove all end plugs from the system by following the fitting-removal instruction on page 6, and please follow the proper fitting installation instruction to prevent any possible leak.

i IMPORTANT! Be careful not to kink any of tubing on the system as kinked tubing can rupture and leak.

1. Connect the WHITE color-coded tubing from the SHOKBLOK protection valve (A) to feed water adapter (B)
2. Connect the BLACK color-coded tubing from drain water connection (C) to Drain saddle (D)
3. Connect the BLUE color-coded tubing from system (E) to Pressurized Water Storage Tank (F)
4. Connect the BLUE color-coded tubing from the system post filter (G) to faucet adapter (H)

Note: if you purchase the optional extra-output kit, please follow to supplied installation instruction first before moving on to the next step.

Dia. I-1

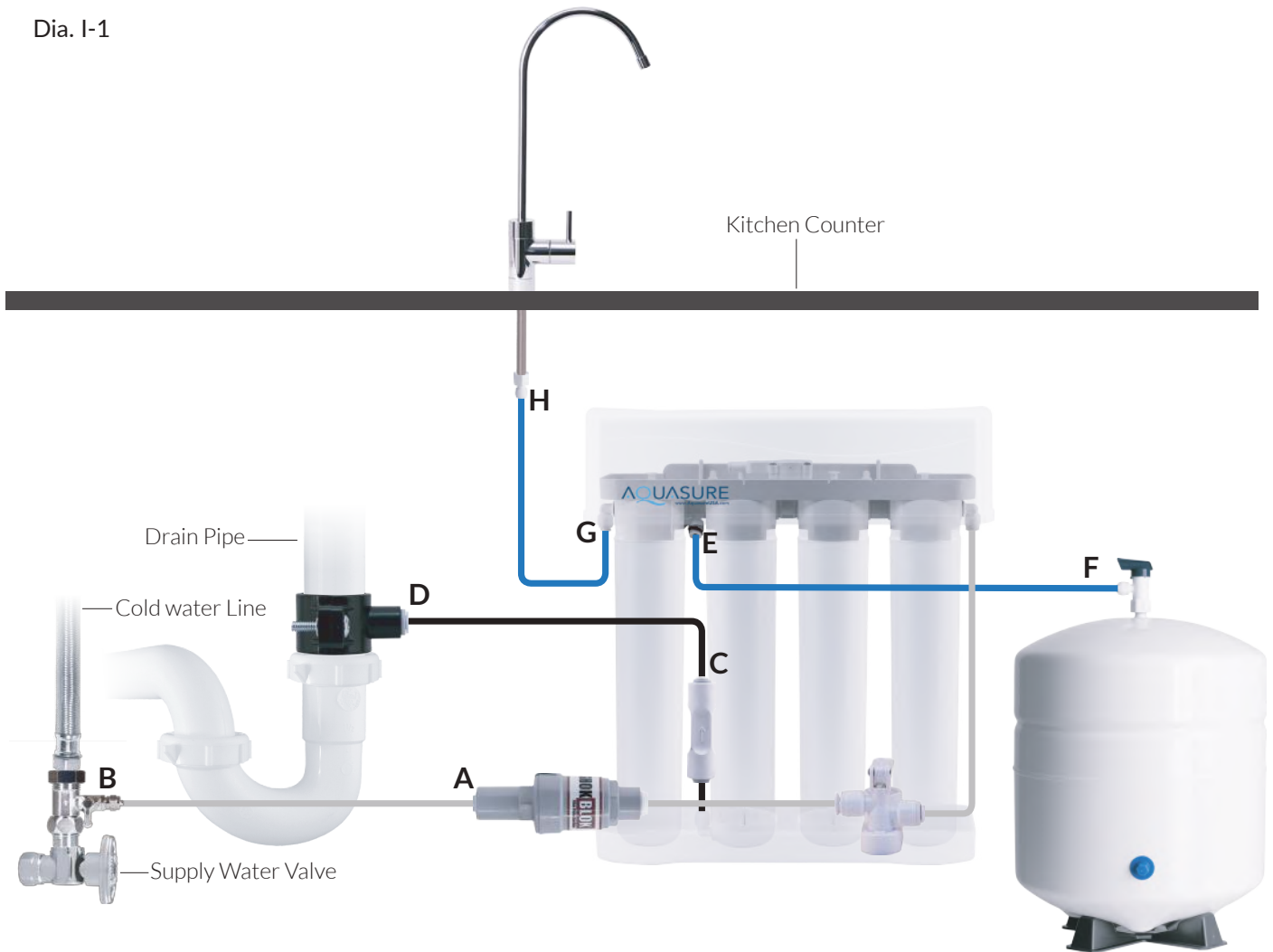

STEP 7. System Startup

⚠ WARNING! Immediately shut off the cold water supply valve or main water supply valve if there are leaks. Check the leak area and see if there's a loose connection or if more Teflon tape is needed to prevent leaks from happening.

1. Turn on the feed water adapter valve and cold water supply valve to allow the water to pass through. (See Diagram J-1)

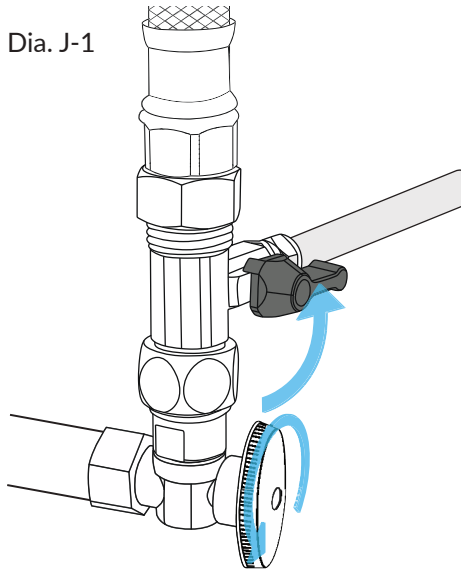

2. Turn on the FLOWLOK™ valve to allow the water to enter the system. (See Diagram J-2)

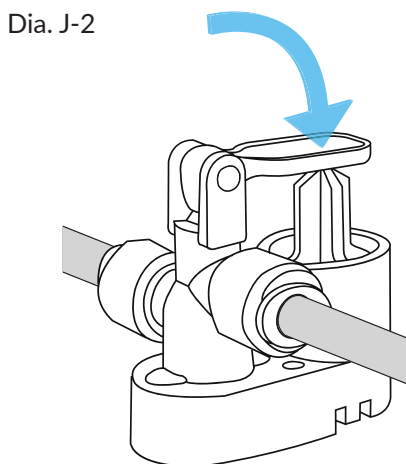

3. Turn on the Tank Ball Valve lever parallel to the tubing connection to allow the water to enter the tank. (See Diagram J-3)

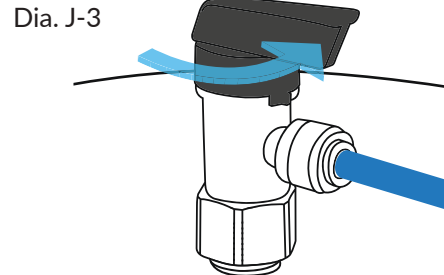

4. Wait 2 to 3 hours for the water storage tank to fill. The system will automatically shut off once the tank is full.
5. Check for leaks! The system is now filled with water and pressurized.
6. Drain out the first tank of water by turning on the dispensing faucet. Have the water run till it becomes a slow stream of water, or when it starts to trickle. (See Diagram J-4)

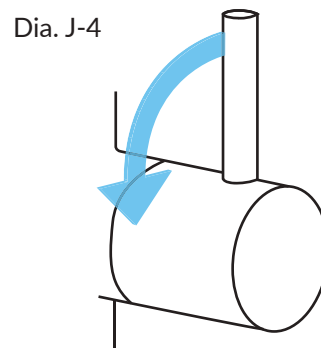

7. Mount the system onto the wall or placed in a secure location.
8. Check one last time on all the connections and joints to make sure there's no leak.

CONGRATULATIONS!

You have finished installing your very own drinking water system. Don't forget to register your system **within 60 days** to get an additional 2 years of warranty coverage.

Simply scan the QR code using your mobile phone, or go directly to our website <http://www.aquasureusa.com/warranty-registration> to begin the online registration process.



SYSTEM MAINTENANCE

Note: The system requires very little maintenance as long as the filter cartridges are regularly replaced at the recommended time frame. Please only use genuine Aquasure replacement filter at www.aquasureusa.com/premier-filters

Filter Replacement Time Frame

- **Pre-Stage Filters:** Replace every 6 to 12 months
(Private well water source may need to replace pre-filters sooner than 12 months due to heavy sediments and other particulates.)
- **RO-Membrane:** Replace every 9 to 12 months
(Private well water source may need to replace membrane sooner than 12 months due to lower source water quality)
- **Post-Stage Taste Refining Filter:** Recommend replacing with the RO-Membrane

CAUTION! Before working on any system maintenance, prepare a clean cloth or microfiber towel to wipe off excess water that might spill during the filter replacements and or system maintenance.

SUBSCRIBE AND SAVE

Save time and money when replacing your Premier Reverse Osmosis filters with our Subscribe and Save program!

Get 25% off your first order and then 10% each order after that.
To find out more...Scan the QR code on the right OR go to aquasureusa.com/subscribeandsave

SCAN ME



I. Removing the FLOWLOK™ Tray

CAUTION! If the system is equipped with FLOWLOK™ leak detector. The tray must be removed before replacing the filters. Failure to do so may cause the safety disc to expand and trip the auto-shut-off safety lever.

1. Remove the FLOWLOK tray by unscrewing the locking screw behind the filters (See Diagram K)
2. Unseat the tray by lowering it from the filters

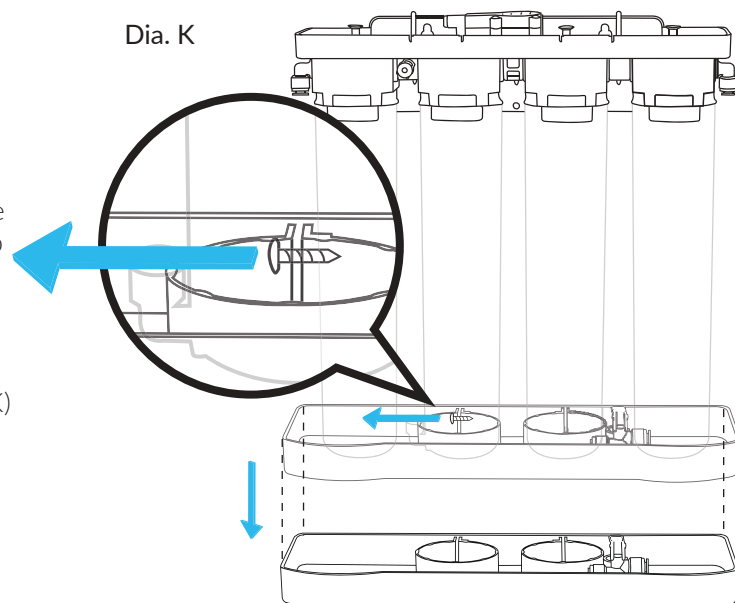

II. Replacing Stage 1 & 2 Pre-Filters

1. Turn OFF tank's ball-valve. (See Diagram L-1)

Dia. L-1

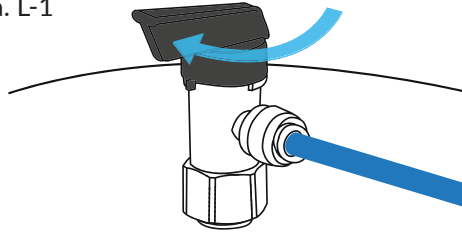

2. Turn OFF cold water supply from feed water adapter to the system. (See Diagram L-2)

Dia. L-2

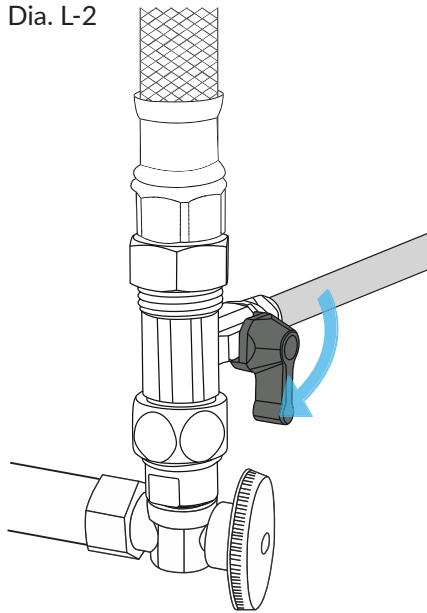

3. Turn on drinking water faucet lever briefly to release the water and relieve the built-up pressure inside the system. This will make removing of filters easier. (See Diagram L-3)

Dia. L-3

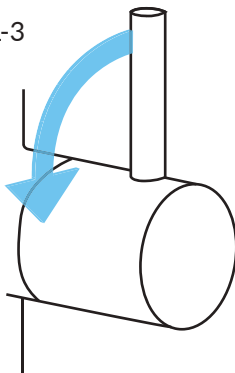

4. Twist the Pre-Stage Filters quarter turn to the right to unseat the filters from the system. (See Diagram L-4)

Dia. L-4

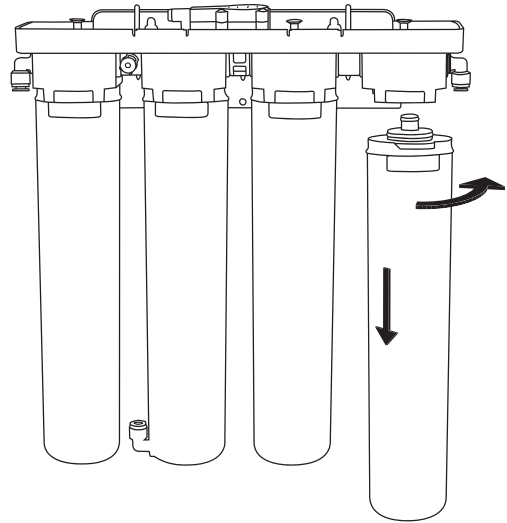

5. Replace the system with new Pre-Stage Filters by setting them on to the system and twisting them quarter turn to the left. (See Diagram L-5)

Dia. L-5

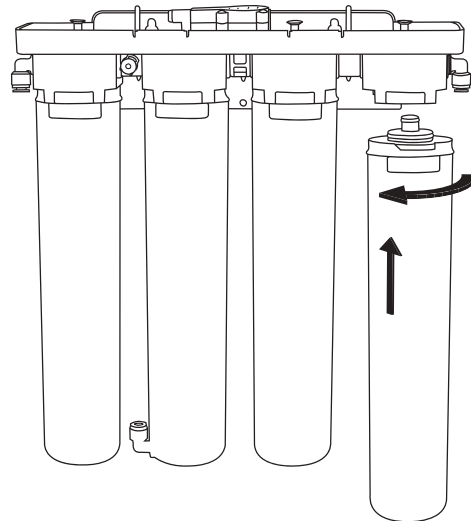

6. Repeat the same process for stage 2.
7. Turn ON cold water supply and Tank Ball Valve.
8. Check for leaks.
9. Secure the FLOWLOK tray by screwing the locking screw behind the filters.

III. Replacing Stage 3 & 4 RO membrane and Post Carbon Filter

1. Turn OFF cold water supply from the feed water adapter to the system.
2. Turn on the dispensing faucet to empty out the tank and store all the product water in a spare water container for usage.
3. When the water starts to trickle, turn OFF tank's ball-valve, but leave the drinking water faucet lever on briefly to release the remaining water and relieve the built-up pressure inside the system. This will make removing of membrane easier.
4. Disconnect the black tubing with the flow restrictor from the Elbow Valve. (See Diagram L-6)
5. Twist the RO-Membrane and Post-Stage Taste Refining Filter quarter turn to the right to unseat the filters from the system.
6. Replace the system with new RO-Membrane and Post-Stage Taste Refining Filter by twisting the filters quarter turn to the left.
7. Make sure the RO-Membrane and Post-Stage Taste Refining Filter are firmly locked in with the system.
8. Re-attached the black tubing with the flow restrictor on to the Elbow Valve.
9. Turn ON cold water supply from feed water adapter and tank ball valve.

Dia. L-6

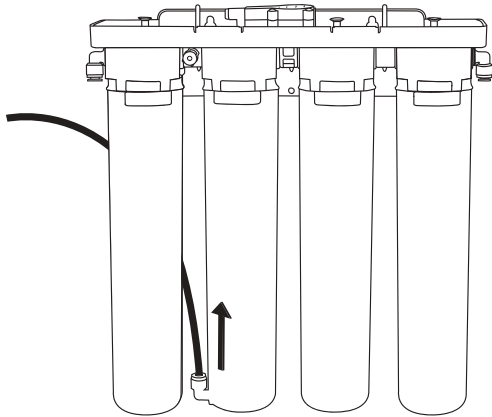

13. Check for leaks.
14. Turn off the dispensing faucet and wait 2 to 3 hours for the water storage tank to fill.
15. Drain out the first tank of water by turning on the dispensing faucet. Have the water run till it becomes a slow stream of water, or when it starts to trickle.
16. Turn off the dispensing faucet to let the water storage tank replenish the product water.
17. Secure the FLOWLOK tray back onto the system.

SYSTEM TROUBLESHOOTING

IMPORTANT! Please shut off cold water supply valve to the system if the system is malfunctioning or leaking and contact our support department immediately!



For any system troubleshooting, feel free to contact our support department at 1-800-661-0680 during our business hour of Monday - Friday from 8:30 am ~ 5:30 pm PDT. You can also e-mail us at support@aquasureusa.com or visit us on the web at <http://www.aquasureusa.com/support> for all the latest update and support.

1. Not enough water from holding tank

	CAUSE:	CORRECTION:
A	Feed water valve is plugged	Open valve or unclog the valve
B	Sediment/Carbon pre-filters or carbon post filter is clogged	Replace the filters
C	Low incoming water pressure	Incoming water pressure must be above the recommended psi level. Install a booster pump if water pressure is lower than the recommended level.
D	Reverse osmosis membrane is fouled	Make sure incoming water pressure is within operating limits. Make sure drain line is not clogged and replace the membrane.
E	Air pressure in holding tank is incorrect	Empty water from holding tank. Air pressure in valve stem should be between 5-10 psi.
F	Air bladder in holding tank is ruptured.	Replace the holding tank
G	Holding tank valve is closed	Open valve
H	No water to drain. Drain flow restrictor is clogged	Replace the drain flow restrictor.
I	Check valve on RO membrane housing is stuck	Replace the RO Membrane

2. Taste and odors in product water

	CAUSE:	CORRECTION:
A	Carbon post filter is exhausted.	Replace the filters
B	There is foreign matter in holding tank.	Clean, flush and sanitize the holding tank. Replace filters.
C	Product water and drain water lines are reversed.	Correct plumbing
D	Dissolved gases in feed water.	Pre-treat feed water to remove gases
E	Increase in product water TDS.	See "Product water is high in total dissolved solids" for troubleshoot.

3. Low water pressure from dispensing faucet

	CAUSE:	CORRECTION:
A	Air pressure in holding tank is incorrect. This is the #1 reason for low flow from reverse osmosis system.	Open faucet and empty water from holding tank. Shut off feed water to system and remove holding tank from under sink. Locate the air valve stem and add air. If there's still water in the tank, continue to add air until all the water is removed. Once all the water is removed, continue to add air and pressurize to 8 psi. Re-install the tank under the sink, turn on the feed water supply to the system and allow the tank to fill.
B	Carbon post filter is clogged	Replace post filter.
C	Holding tank valve is partially closed	Open tank ball valve fully.
D	The faucet is out of adjustment or faulty.	Repair or replace the faucet
E	Heavy water use. Holding tank is empty.	Allow holding tank to refill for about an hour or so before using the water.
F	Low water production	See "Not enough water from holding tank" for troubleshoot.

4. Drain water overflows at the air gap faucet

	CAUSE:	CORRECTION:
A	Air gap is clogged	Clear Air Gap
B	Drain line is clogged	Clear Tubing
C	Drain flow rate is too high	Replace flow restrictor

5. Product water is high in total dissolved solids (TDS)

	CAUSE:	CORRECTION:
A	Clogged pre-filters	Replace Filter
B	Low Incoming water pressure	Incoming water pressure must be above 40 psi. Install a booster pump or permeate pump
C	Reverse osmosis membrane is expanded	If membrane life is unusually short, check the TDS level of incoming water to see if it exceed the range of recommended operating condition. Pretreatment may be needed if the incoming TDS level is too high. An average life of membrane should be around 2 - 3 years. Replace the RO membrane
D	Product water and drain water line are reversed	Check the connection and correct plumbing
E	No water to drain. Drain flow restrictor is clogged.	Replace drain flow restrictor
F	No water to drain. Air Gap faucet is clogged.	Clear or replace air gap faucet
G	The automatic shut-off is not closing	Repair or replace automatic shut-off valve
H	New carbon post-filter has not been rinsed completely	Drain holding tank twice to rinse new carbon post-filter
I	The incoming feed water TDS has increased	An increase in feed water TDS will also give an increase in product water TDS

6. Faucet leaks or drips

	CAUSE:	CORRECTION:
A	Water leaks from faucet spouts	Adjust the faucet by turning the tee bar located under the handle to provide a small amount of free play in the handle when shut off. Should this not work, repair or replace the faucet.
B	Water leaks from beneath the handle	Repair or replace the faucet.

7. Little to no water at dispensing faucet.

	CAUSE:	CORRECTION:
A	Water is shut off at stop valve	Open main stop valve.
B	Flowlok is set to off position	Make sure Flowlok main lever is in open position. Lever should be lowered.
C	Output line is crimped	Reroute the line so they are not restricting the water from existing the faucet.
D	Tank is not pre-charged	Empty out the tank and recharge the tank pressure
E	Tank is defective or does not hold pressure	Replace the tank
F	Tank is not filled with water yet	Allow holding tank to refill for about an hour or so before using the water.
G	Insufficient water pressure	Incoming water pressure must be above 40 psi. Install a booster pump.
H	Incorrect installation	Check the installation guide and make sure all the steps are installed properly.

8. System makes humming noise

	CAUSE:	CORRECTION:
A	Air bubble trapped inside the housing	Purge the air by tilting the system on one side, shut off the tank ball valve and turn on the dispensing faucet for about 1 minute. Repeat 3 or 4 time to purge out all the air.

9. Tank takes a long time to fill

	CAUSE:	CORRECTION:
A	Insufficient water pressure	Incoming water pressure must be above 40 psi. Install a booster pump.
B	Lower water temperature	Cold water affects the performance of system. Install a booster pump to compensate for lower water temperature.

10. System slow to shut off

	CAUSE:	CORRECTION:
A	Insufficient water pressure for system to shut off	Incoming water pressure must be above 40 psi. Install a booster pump.
B	Feed water valve is not open fully	Open feed water valve fully to lessen the restricted flow
C	Sediment/Carbon pre-filters is clogged	Replace the filter

11. System does not shut off

	CAUSE:	CORRECTION:
A	Automatic shut-off valve is defective	Test the functionality of automatic shut-off valve by closing the tank ball valve to see if the system will shut off. If the system continues producing water, the automatic shut-off valve is defective and needs to be replaced.
B	Automatic shut-off valve is not defective and incoming water pressure is too low	Incoming water pressure must be above 40 psi. Install a booster pump.
C	System is feeding multiple outlets or an outlet that demands water constantly.	It is normal in this situation as system needs to constantly produce water to supply the multiple outlets.

MANUFACTURER'S WARRANTY

1-YEAR LIMITED WARRANTY

For AQUASURE Drinking Water Systems

AQUASURE Drinking Water Systems warrants product to be free from defects in material and workmanship for a period of twelve (12) months from the date of purchase. During this time, we will repair or replace, at its option, any AQUASURE Drinking Water System. Please request and RMA and upon RMA approval return the AQUASURE Drinking Water Systems and we will either make the necessary repairs or, if it is determined that a replacement is required, we will provide a replacement part. This warranty does not include shipping and handling charges which will be collected from you by the dealer. Parts repaired or replaced under this one (1) year warranty will be covered under warranty to the end of the original one (1) year warranty period. This warranty is also subject to the conditions and limitations outlined under the heading "General Conditions and Limitations" section.

ONE-YEAR LIMITED PRORATED WARRANTY

For Structural, Hardware and Electrical Components

AQUASURE Drinking Water Systems warrants the structural, hardware, and any electrical components to be free from defects in material and workmanship for a period of one (1) year pro-rated from the date of purchase. During this time, we will repair or replace, at its option, any defective parts covered by the warranty. Defective part(s) will need to be returned to AQUASURE. We will either make the necessary repairs or, if it is determined that a replacement is required, we will provide a replacement part. We will then return the part to the buyer. This warranty does not include shipping and handling charges which will be collected from you. Parts repaired or replaced under this one (1) year pro-rated warranty will be covered under warranty to the end of the original one (1) year prorated warranty period. This warranty is also subject to the conditions and limitations outlined under the heading "General Conditions and Limitations" section.

One-Year Limited Warranty for fittings, tubing, valves, flow-lok and shok blok.

AQUASURE Drinking Water Systems warrants these parts to be free from defects in material and workmanship for a period of one (1) year from the date of purchase. During this time, we will repair or replace, at its option, any defective parts covered by the warranty. The warranty may be verified using date codes in addition to purchase receipts and AQUASURE Drinking Water System's database of serial number sales date. We will advise you whether the defective item needs to be returned to the AQUASURE Drinking Water Systems dealer you purchased the equipment from for failure analysis. Replacement parts provided under warranty will be sent to your AQUASURE Drinking Water Systems dealer. Parts replaced under this one (1) year warranty will be covered under warranty to the end of the original one (1) year warranty period. This warranty is also subject to the conditions and limitations outlined under the heading "General Conditions and Limitations" section.

General Conditions and Limitations

None of the above warranties cover damage caused by improper use or maintenance, accidents, acts of God or minor scratches or imperfections that do not materially impair the operation of the product. The warranties also do not cover products that are not installed as outlined in the applicable Owner's Manual. AQUASURE Drinking Water Systems System warranty will be deemed null and void if any of the product labels are removed. The limited warranties described above are the only warranties applicable to the AQUASURE Drinking Water Systems products. These limited warranties outline the exclusive remedy for all claims whether based on contract, tort (including negligence), strict liability or otherwise. Disclaimer of warranties. Except as expressly warranted in writing by, the goods sold by AQUASURE are purchased by the buyer "as is." AQUASURE does not warrant that the goods are of merchantable quality or that they can be used for any particular purpose. Except as expressly warranted in writing by AQUASURE, AQUASURE makes no representation or warranty of any kind with respect to the products.

Non-Covered Defects

THIS LIMITED PRODUCT WARRANTY DOES NOT COVER DEFECTS CAUSED BY:

1. Improper storage, installation, maintenance, handling, use and/or alterations of the Product, including, but not limited to, noncompliance with the installation, maintenance and standard operation conditions stated in the Manual and this Limited Product Warranty.
2. Unreasonable use, unintended use, or misuse of the Product for something other than its intended purpose as a drinking water system.
3. Use of replacement parts, filters, membranes or other accessories that are not sold or manufactured by Aquasure for use with this particular Product.
4. Damage not resulting from manufacturing defects that occur while the Product is in the original purchaser's possession.
5. Installation of the Product with known or visible manufacturing defects at the time of installation.
6. Damage caused by freezing, flood, fire or Act of God.

Condition that render this limited product warranty void

THIS LIMITED PRODUCT WARRANTY SHALL BE VOID IF:

1. The Product is not operated in compliance with normal municipal water conditions for which the particular model of this Product is intended.
2. The person seeking to invoke the warranty is not the original purchaser. That is, this Limited Product Warranty only extends to original purchasers.
3. The product is purchased used. That is, this Limited Product Warranty only covers new products.
4. The Product is purchased from someone other than Aquasure or one of Aquasure's authorized dealers. This is because, unless the Product was sold by Aquasure or one of its authorized dealers, Aquasure cannot verify or guarantee the integrity or authenticity of the Product.

Limitation of liability.

In no event shall AQUASURE be liable to the purchaser or any other entity for more than the invoice price received by AQUASURE for any non-conforming products. AQUASURE shall not be liable to the purchaser or any other entity for personal injury, property damage, or any direct, indirect, special, incidental, consequential, punitive, exemplary, or other damages of any kind, including without limitation the cost of procurement of substitute goods, the loss of profits, products, or production, or the interruption of business, however caused and on any theory of liability, and whether or not AQUASURE has been advised of the possibility of such damages. The essential purpose of this provision is to limit the liability of AQUASURE arising out of the sale of products to the purchaser whether for breach of contract, negligence, or otherwise. These limitations shall apply notwithstanding any failure of essential purpose of any limited remedy and notwithstanding the provisions of any other agreement between AQUASURE and the purchaser.

Obtaining Warranty Coverage or General Inquiries

If coverage is available, you may obtain coverage under this Limited Product Warranty by providing Aquasure with proof of original purchase, and that you are the original purchaser. For service under this Limited Product Warranty, you must notify Aquasure by phone at 1-800-661-0680, by email at support@aquasureusa.com, or in writing at 12403 Central Ave #536, Chino, CA 91710. In making the claim, please provide your name, address, phone number, a description of the product involved, and an explanation of the defect.

GENERAL CONDITIONS AND LIMITATIONS

The products described in this document are hereby offered for sale to be established by Aquasure any of its subsidiaries and its authorized distributors. This offer and its acceptance by any customer (the "Buyer") shall be governed by all of the following Terms and Conditions. Buyer's order for any item described in this document, when communicated to Aquasure, its subsidiaries or an authorized distributor (the "Seller") verbally or in writing, shall constitute acceptance of this offer. Provided, however, that these terms and conditions shall not operate as a rejection of the Buyer's offer unless such offer contains variances in the description, quantity, price, or delivery schedule of the items.

1. Terms and Conditions of Sale.

All descriptions, quotations, proposals, offers, acknowledgments, acceptances and sales of the Seller's products are subject to and shall be governed exclusively by the terms and conditions stated herein (the "Agreement"). The Buyer's acceptance of any offer to sell is limited to the terms and conditions in the Agreement. Any terms or conditions in addition to or inconsistent with those stated in the Agreement, proposed by the Buyer in any acceptance of an offer by the Seller, are hereby rejected. No such additional, different or inconsistent terms and conditions shall become part of the agreement between the Buyer and the Seller unless expressly accepted in writing by the Seller. The Seller's acceptance of any offer to purchase by the Buyer is expressly conditioned upon the Buyer's assent to all the terms and conditions in this Agreement, irrespective of any terms in addition to, or inconsistent with those contained in the Buyer's offer. Acceptance of the Seller's products shall in all events constitute such assent.

2. Documents.

Unless provided otherwise in the Agreement, all catalog descriptions, illustrations, drawings and literature or independently submitted estimates of performance, weights and measurements or other specifications provided by the Seller are mere approximations and the Seller reserves the right to alter or amend them at any time. The Seller reserves the right to correct clerical or technical errors in the contract documents. The Buyer shall furnish with his order all necessary specifications and information. The Seller takes no responsibility for goods manufactured, priced or delivered not in accordance with the order or the specifications unless the Buyer's order and specifications are clear and correct.

3. Prices.

Unless otherwise provided, all prices contained in our quotations and written acceptances are ex-works and do not include the cost of packing. All orders are accepted on the condition that all such prices are subject to revision by the Seller at any time before the goods are dispatched to take account of any price change. In the event that the Buyer does not place the entire order quoted by the Seller for the Buyer, the Seller reserves the right to revise its prices. The Seller also reserves the right to revise its prices if the Buyer modifies the specification or quantity of the goods or the delivery requirements after the order has been accepted by the Seller.

4. Advice.

All advice given in connection with the Seller's goods is provided without charge to the Buyer. ANY ADVICE AND ASSISTANCE GIVEN BY THE SELLER TO THE BUYER IS GIVEN AT THE BUYER'S RISK, AND THE SELLER SHALL NOT BE LIABLE FOR ANY LOSS, DAMAGE OR CLAIM ARISING THERE FROM Unless otherwise provided in the Agreement, or explicitly agreed upon in writing by the Seller, payment is due in accordance to the terms upon placement of order. If credit terms are in effect at time of purchase payment is due in full in 30 days, days from date of shipment of the items purchased herein under.

(a) Amounts not timely paid shall bear interest at the rate of 2-1/2% above the Seller's bank's prime rate from time to time in force.

(b) In the event that the Buyer fails within one calendar month of the date for payment to effect any payment which may be due under the Agreement or any agreement with the Seller, or if the Buyer commits any breach of the Agreement, or if the Buyer becomes insolvent or commits any act of bankruptcy or contemplation of liquidation, the Seller will be entitled, without prejudice to the Seller's other rights, to terminate the Agreement or any unfulfilled part thereof, or at the Seller's option to make partial deliveries.

5. Modifications and Cancellations.

This Agreement is not subject to oral modification or cancellation. A Buyer's request for modification or cancellation will not be incorporated into the Agreement unless the request is accepted by the Seller in a writing that amends the Agreement. Acceptance of any such requested modification or cancellation shall be at the Seller's discretion and shall be upon such terms and conditions as the Seller may require.

6. Handling Charge.

Goods supplied in accordance with the Buyer's order may later be returned to the Seller at the Seller's discretion provided the return is pre-authorized in writing, and the merchandise is unused, in original packages, unaltered, clean and no older than 60 days from the date of shipment by the Seller. The Buyer will be required to pay to the Seller a handling charge of 25% of the purchase price of the returned goods. A copy of the original invoice for the merchandise must accompany all returns.

7. Delivery.

(a) Any delivery dates quoted are approximate only and the Seller shall have no liability for any delays in delivery.

(b) Delivery of goods purchased from 3rd party marketplace are solely marketplace's responsibility and Seller will not be responsible for any delay, missing or unshipped goods sent from 3rd party marketplace.

(c) Unless provided otherwise, delivery of the goods shall be made when the Seller has notified the Buyer that the goods are ready for dispatch. Regardless of the method of delivery, delivery shall be made F.O.B. Seller's plant, where the risk of loss shall thereupon pass to the Buyer upon the Seller's delivery to a carrier. Notwithstanding that the Seller's prices are ex-works, the Seller is prepared by special contract to procure carriage or freight and insurance on behalf of the Buyer and at Buyer's cost in which event the Seller shall be under no liability for damage in transit or loss or damage to the goods beyond the point at which the Seller contracts to deliver the same.

8. Inspection and Rejection.

(a) The following provisions shall apply in relation to all deliveries of goods: the Seller shall not be held liable for any claims of damage in transit, shortage of delivery or loss of goods, unless in the case of shortage of delivery, a separate notice in writing is given to the carrier concerned and to the Seller within three (3) days of the receipt of the goods, followed by a complete claim in writing within five (5) days of receipt of the goods and in the case of loss of goods, a separate notice in writing is given to the carrier concerned and to the Seller and a complete claim in writing made within thirty (30) days of the date of consignment. The Buyer must inspect the goods on arrival from the carrier; however, where goods are accepted from the carrier concerned without being inspected, the delivery book of the carrier concerned must be signed "not examined". The Seller shall have the right to inspect the goods at the Buyer's premises in respect to any such claims made by the Buyer and the Buyer shall retain such goods until the Seller has inspected such goods or until the Seller has notified the Buyer that the Seller does not wish to inspect such goods. Any breach of these conditions in this provision shall serve as a waiver to any claim brought by the buyer.

(b) Without prejudice to the Seller's other rights, should the Buyer fail for any reason to send the Seller forwarding instructions within ninety (90) days after the date of the Seller's notification that the goods are ready for dispatch or to accept delivery of the goods, the Seller shall be entitled at the Buyer's risk and expense to store the goods and/or to procure or effect storage of the goods elsewhere. Goods so stored shall be paid for as if they had been dispatched and/or accepted

9. Test and Performance.

(a) The Seller's goods are, where practicable, submitted to the Seller's standard test before delivery. If special tests are required, these shall be made at the Seller's premises unless otherwise agreed, and will be subject to an extra charge.

(b) The Seller accepts no liability for failure to attain any performance figures quoted by the Seller unless the Seller specifically has guaranteed them with an agreed sum as liquidated damages and the Buyer has suffered actual loss by reason of the failure to attain the figures quoted.

(c) Any particulars of weights and measurements, power and consumption, power output or performance relating to the goods and like matters furnished by the Seller to the Buyer in the Seller's catalogs, literature or otherwise, are approximate and are intended only to present a general idea of the goods to be supplied and unless previously agreed specifically in writing shall not form part of the Agreement.

10. Taxes.

Unless otherwise indicated, all prices and charges are exclusive of excise, sales, use, property, occupational or like taxes which may be imposed by any taxing authority upon the manufacture, sale or delivery of the items sold hereunder. If any such taxes must be paid by the Seller, or if the Seller is liable for the collection of such tax, the amount thereof shall be in addition to the amounts for the item sold. The Buyer agrees to pay all such taxes or to reimburse the Seller therefore upon receipt of its invoice. If the Buyer claims exemption from any sales, use or other tax imposed by any taxing authority, the Buyer shall promptly indemnify and hold the Seller harmless from and against any such tax, as well as any interest or penalties thereon which may be assessed if the items are held to be taxable.

11. Warranty.

EXCEPT AS EXPRESSLY WARRANTED IN WRITING BY THE SELLER, THE GOODS SOLD BY THE SELLER ARE PURCHASED BY THE BUYER "AS IS." THE SELLER DOES NOT WARRANT THAT THE GOODS ARE OF MERCHANTABLE QUALITY OR THAT THEY CAN BE USED FOR ANY PARTICULAR PURPOSE. EXCEPT AS EXPRESSLY WARRANTED IN WRITING BY THE SELLER, THE SELLER MAKES NO REPRESENTATION OR WARRANTY OF ANY KIND WITH RESPECT TO THE PRODUCTS.

(a) The Seller warrants that the items sold hereunder shall be free from defects in material or workmanship at the time of shipment by the Seller. The Seller warrants that if within 12 months of delivery of the goods to the Buyer the Buyer returns immediately to the Seller's premises any of the said goods which the Buyer believes to be defective, carrier paid, properly packed and clearly marked with the Buyer's full name and address and any other information such as serial numbers which may be necessary to enable the goods to be identified, together with a complete description of the alleged defect, they will be repaired or new goods will be supplied in exchange and the goods so repaired or such new goods will be delivered to the Buyer free of charge at the Seller's premises; provided, however, that the foregoing warranty shall be applicable only if upon demand by the Seller, the Buyer proves to the Seller's satisfaction: (i) that the defect was due solely to defective workmanship; (ii) that no alterations or repairs have been made to the goods except with the Seller's written consent; (iii) that the defect was not caused by any act of the Buyer or its agents; and (iv) that the defect was not caused by any matter beyond the reasonable control of the Seller, including, without limitation, accident or normal wear and tear.

(b) THIS WARRANTY DOES NOT APPLY UNLESS THE SELLER'S PRODUCTS ARE: (I) USED IN DOMESTIC PLUMBING APPLICATIONS; (II) INSTALLED BY A LICENSED CONTRACTOR, PLUMBER OR QUALIFIED EQUIPMENT INSTALLATION PROFESSIONAL; AND (III) INSTALLED AND OPERATED IN ACCORDANCE WITH PUBLISHED AQUASURE DRINKING WATER SYSTEM SPECIFICATIONS.

(c) All costs and expenses, including freight charges, customs duties, and insurance incurred in returning the goods to the Seller's premises in accordance with this provision shall be paid by the Buyer. The benefit of this warranty shall not be assignable by the Buyer.

(d) THIS WARRANTY DOES NOT EXTEND TO ANY GOODS NOT MANUFACTURED BY THE SELLER EVEN THOUGH SUPPLIED BY THE SELLER NOR DOES IT EXTEND TO ANY SECOND-HAND OR RECONDITIONED GOODS NOR DOES IT EXTEND TO COMPONENTS MANUFACTURED BY THE SELLER BUT INSTALLED, ATTACHED OR WELDED BY THE BUYER OR HIS CUSTOMER ON EQUIPMENT NOT MANUFACTURED BY THE SELLER. GOODS NOT MANUFACTURED BY THE SELLER CARRY ONLY THE WARRANTY (IF ANY) OF THEIR MAKERS AND THE BUYER IS ENTITLED TO THE BENEFIT THEREOF ONLY SO FAR AS THE SELLER HAS THE POWER TO TRANSFER IT.

(e) THIS WARRANTY COMPRISES THE SOLE AND ENTIRE WARRANTY PERTAINING TO ITEMS PROVIDED HEREUNDER; THE SELLER MAKES NO OTHER WARRANTY, GUARANTEE, OR REPRESENTATION OF ANY KIND WHATSOEVER. ALL OTHER WARRANTIES, INCLUDING BUT NOT LIMITED TO MERCHANTABILITY AND FITNESS FOR PURPOSE, WHETHER EXPRESSED OR IMPLIED, OR ARISING BY OPERATION OF LAW, TRADE USAGE, OR COURSE OF DEALING, ARE HEREBY DISCLAIMED.

(f) NOTWITHSTANDING THE FOREGOING, THERE ARE NO WARRANTIES WHATSOEVER ON ITEMS BUILT OR ACQUIRED WHOLLY OR PARTIALLY TO THE BUYER'S DESIGNS OR SPECIFICATIONS.

12. Limited Remedy.

THE SELLER'S LIABILITY ARISING FROM OR IN ANY WAY CONNECTED WITH THE ITEMS SOLD OR THIS AGREEMENT SHALL BE LIMITED EXCLUSIVELY TO REPAIR OR REPLACEMENT OF THE ITEMS SOLD. IN NO EVENT SHALL THE SELLER BE LIABLE TO THE BUYER OR ANY THIRD PARTY FOR ANY INCIDENTAL, CONSEQUENTIAL OR SPECIAL DAMAGES OF ANY KIND OR NATURE WHATSOEVER, INCLUDING BUT NOT LIMITED TO LOST PROFITS ARISING FROM OR IN ANY WAY CONNECTED WITH THIS AGREEMENT OR ANY ITEMS SOLD, WHETHER ALLEGED TO ARISE FROM BREACH OF CONTRACT, EXPRESS OR IMPLIED WARRANTY, OR IN TORT, INCLUDING WITHOUT LIMITATION, NEGLIGENCE, FAILURE TO WARN OR STRICT LIABILITY. IN NO EVENT SHALL THE SELLER BE LIABLE TO THE BUYER OR ANY OTHER ENTITY FOR MORE THAN THE INVOICE PRICE RECEIVED BY THE SELLER FOR ANY NON-CONFORMING PRODUCTS. THE SELLER SHALL NOT BE LIABLE TO THE BUYER OR ANY OTHER ENTITY FOR PERSONAL INJURY, PROPERTY DAMAGE, OR ANY DIRECT, INDIRECT, SPECIAL, INCIDENTAL, CONSEQUENTIAL, PUNITIVE, EXEMPLARY, SPECIAL, OR OTHER DAMAGES OF ANY KIND, INCLUDING WITHOUT LIMITATION THE COST OF PROCUREMENT OF SUBSTITUTE GOODS, THE LOSS OF PROFITS, PRODUCTS, OR PRODUCTION, OR THE INTERRUPTION OF BUSINESS, HOWEVER CAUSED. THE SELLER SHALL NOT BE LIABLE TO THE BUYER OR ANY OTHER ENTITY ON ANY THEORY OF LIABILITY INCLUDING WITHOUT LIMITATION BREACH OF CONTRACT OR EXPRESS OR IMPLIED WARRANTY, TORT, NEGLIGENCE, FAILURE TO WARN, OR STRICT LIABILITY, AND WHETHER OR NOT THE SELLER HAS BEEN ADVISED OF THE POSSIBILITY OF SUCH DAMAGES. THE ESSENTIAL PURPOSE OF THIS PROVISION IS TO LIMIT THE LIABILITY OF THE SELLER ARISING OUT OF THE SALE OF PRODUCTS TO THE BUYER WHETHER FOR BREACH OF CONTRACT, NEGLIGENCE, OR ANY OTHER THEORY OF LIABILITY. THESE LIMITATIONS SHALL APPLY NOTWITHSTANDING ANY FAILURE OF ESSENTIAL PURPOSE OF ANY LIMITED REMEDY AND NOTWITHSTANDING THE PROVISIONS OF ANY OTHER AGREEMENT BETWEEN THE SELLER AND THE BUYER.

13. Indemnity for Infringement of Intellectual Property Rights.

(a) The Buyer shall defend and indemnify the Seller against all actions, claims, demands, penalties and costs by third parties in tort, or for infringement, or alleged infringement, of patents, trademarks, copyrights, trade dress, trade secret or other rights of any third party resulting from the goods manufactured in accordance with the Buyer's specifications or based on any information provided by the Buyer. The Buyer will defend any action against the Seller for title, patent, trademark, copyright infringement, or other claimed by a third party at the Buyer's sole cost and expense.

(b) The Seller shall have no liability for infringement of any patents, trademarks, copyrights, trade dress, trade secrets or similar rights except as provided in this provision. The Seller will defend and indemnify the Buyer against allegations of infringement of patents, trademarks, copyrights, trade dress and trade secrets ("Intellectual Property Rights"). The Seller will defend at its expense and will pay the cost of any settlement or damages awarded in an action brought against the Buyer based on an allegation that an item sold pursuant to this contract infringes the Intellectual Property Rights of a third party. The Seller's obligation to defend and indemnify the Buyer is contingent on the Buyer notifying the Seller within 10 days after sole control over the defense of any allegations or actions, including all negotiations for settlement or compromise. If an item sold hereunder is subject to a claim that it infringes the Intellectual Property Rights of a third party, the Seller may, at its sole expense and option, procure for the Buyer the right to continue using said item, replace or modify said item so as to make it non-infringing, or offer to accept return of said item and return the purchase price less a reasonable allowance for depreciation.

Notwithstanding the foregoing, the Seller shall have no liability for claims of infringement based on information provided by Buyer, or directed to items delivered hereunder for which the designs are specified in combination or use in a system of any item sold hereunder. The foregoing in this provision shall constitute the Seller's sole and exclusive liability and the Buyer's sole and exclusive remedy for infringement of Intellectual Property Rights.

14. Waiver.

The Seller's rights shall not be affected or restricted by any indulgence or forbearance granted to the Buyer. No waiver by the Seller of any breach shall operate as a waiver of any later breach.

15. Force Majeure.

The Seller shall be excused from performing any of its obligations under this Agreement which are prevented or delayed by any occurrence not within the reasonable control of the Seller, including but not limited to, accidents, acts of God, destruction or damage to the goods or the Seller's manufacturing plant, delays or failures in delivery of carriers or suppliers, shortages of materials, strikes or other labor matters, floods, earthquakes, fire, riots, explosions, or any regulations, rules, ordinances or orders of any governmental authority, federal, state or local, whether such cause exists at the date of the order or not.

16. Buyer's Representation of Solvency.

The Buyer hereby represents that as of the signing of this Agreement it was not insolvent within the meaning of the Uniform Commercial Code or any Bankruptcy Laws.

17. Assignment and Delegation.

The rights and obligations of the parties under this Agreement may not be assigned or delegated, except on the express written consent of the other party to the assignment or delegation.

18. Integration.

The rights and obligations of the parties and the terms and conditions set forth herein, together with any amendments, modifications and any different terms and conditions expressly accepted by the Seller in writing, shall constitute a complete and exclusive statement of the terms of this Agreement. This Agreement supersedes not only all prior agreements, but also oral agreements made contemporaneously with the execution of this Agreement. All such materials may not be used to supplement, explain, or contradict the terms of this Agreement.

19. Severability.

If any of these conditions or any part thereof purports to exclude or restrict or limit any liability and such exclusion or restriction or limitation is prohibited or rendered void or unenforceable by any legislation to which it is subject, or is itself prohibited or rendered void or unenforceable by any legislation to which it is subject, then the exclusion, restriction or limitation on the condition or part thereof in question shall be so prohibited or rendered void or unenforceable and the validity or enforceability of any other part of these provisions shall not thereby be affected.

20. Governing Law/Limitation on Actions.

The terms, conditions, rights, and obligations under this Agreement shall be construed under the laws of the State of California, without regard to principles of conflicts of laws. No actions arising out of the sale of the items sold hereunder or this Agreement may be brought by the Buyer more than two (2) years after such cause of action accrues.

AQUASURE