

# AQUASURE

Serene Salt-Free Lite



**⚠ IMPORTANT!**  
For optimum performance and protection against contaminants, please fully read this owner's manual before proceeding with installation.

V1002 • 01/24 © Aquasure USA - All Rights Reserved

Size: 8.5" x 11"



# TABLE OF CONTENT

---

<u>WELCOME &amp; CONGRATULATIONS</u>	<u>1</u>
<u>EXTENDED WARRANTY REGISTRATION</u>	<u>2</u>
<u>INSPECTION &amp; PREPARATION</u>	<u>3</u>
I. Be familiar with the system before installation	
II. System Operation Parameter and Installation checklist	
III. Installation Safety Guide	
<u>INSTALLING THE SYSTEM</u>	<u>6</u>
STEP 1. Checking the Direction of Water Flow	
STEP 2. Shutting Off the Main Water Supply Valve	
STEP 3. Mounting the Pre-Filter	
STEP 4. Attaching the Water Supply to the Pre-Filter	
STEP 5. Installing the Pre-Filter Cartridge	
STEP 6. Connecting the Plumbing onto the Valve	
STEP 7. System Startup	
<u>REVERSE OSMOSIS EXCLUSIVE DISCOUNT!</u>	<u>11</u>
<u>SYSTEM MAINTENANCE</u>	<u>13</u>
STEP 1. Shut Off the Supply Water	
STEP 2. Remove the Filter Housing	
STEP 3. Install the New Filter	
STEP 4. System Startup	
<u>SUBSCRIBE AND SAVE</u>	<u>14</u>
<u>LIMITED PRODUCT WARRANTY</u>	<u>15</u>

# WELCOME & CONGRATULATIONS

---

Thank you for choosing Aquasure. This owner's manual will provide general installation guidance for the Aquasure Serene Series Salt-Free Lite Water Conditioning System.

**For MAXIMUM effectiveness please thoroughly read this manual.**

 **IMPORTANT!** This owner's manual serves as a source of general guidance; nevertheless, it is crucial to emphasize that errors during installation may result in system malfunction and can potentially void the warranty. Therefore, it is strongly recommended to engage the services of a licensed plumber for professional installation. In the event that you need support, our Aquasure technicians are available to answer any questions during hours of operation as listed below.

**Hours of Operation:** M-F 8:30AM - 5:30PM PST

**Telephone:** 1800-661-0680

**Email:** [support@aquasureusa.com](mailto:support@aquasureusa.com)

**Online Chat:** [aquasureusa.com/support](http://aquasureusa.com/support)

# DON'T MISS OUT ON FOUR FREE YEARS WITH AQUASURE'S EXTENDED WARRANTY

Register your product within 60 Days from time of purchase to keep your full 5 year warranty. Simply visit [aquasureusa.com/support](http://aquasureusa.com/support) and enter your purchase and serial number. Or fill out the information below and follow the steps.

Fill in the information below for future reference and submit using the instructions below to receive the extended 4 year product warranty..

Purchaser Name: \_\_\_\_\_

Email: \_\_\_\_\_

Phone: \_\_\_\_\_

Address: \_\_\_\_\_

\_\_\_\_\_

City: \_\_\_\_\_

State: \_\_\_\_\_

Zip: \_\_\_\_\_

Order Number: \_\_\_\_\_

Order Date: \_\_\_\_\_

Serial Number: \_\_\_\_\_

Place of Order: \_\_\_\_\_

## Registration with your mobile device is easy.

1. Fill out the form by handwriting your info.
2. Take a picture of the form with your device.
3. Scan the QR code with your device camera and click the banner that appears.
4. Attach the picture of the form to the email that opens.
5. Hit Send and you're DONE!

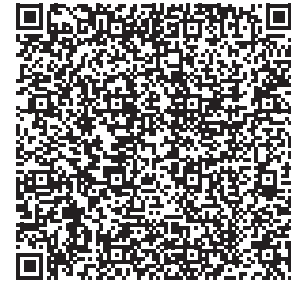

## Where to find your Serial Number



# INSPECTION & PREPARATION

## I. Be Familiar with the System Before Installation

**i** **IMPORTANT!** Please read the entire manual and become familiar with instructions and parts needed before proceeding with the installation.

### Inspect the System

Take the system and all the components out of the box and inspect them carefully, making sure nothing was damaged during shipping. If any part is cracked or broken, do not proceed with the installation and contact Aquasure or your distributor for an exchange or diagnosis.

### System Components Breakdown for Serene Series Salt-Free Lite Water Conditioning System

#### SCZ Triple-Purpose Pre-Filter\*

##### Parts:

- Aquasure High-Flow Housing
- Aquasure SCZ Triple-Purpose Filter\*
- Aquasure Housing Wrench
- Aquasure Housing Mounting Bracket
- Nipple 1" to 1" x 2
- Nipple 1" to 3/4" x 2
- Mounting Bolts x 8
- Washers x 8

#### Serene Salt-Free Water Conditioning System

##### Parts:

- Aquasure Pre-Filled Salt-Free Media Tank
- Aquasure SF Lite Valve Head
- Upper Distribution Basket



\*Pre-filter is subject to change based on system/ bundle.

### Recommended Tool List for System Installation

- Variable Speed Drill
- Drill Bit
- Bolt Bit
- Adjustment Wrench
- Level Tool
- Teflon Tape
- Pen or Pencil

### Recommended Parts List for System Installation

- 1" Male Thread Adapter X 4
- 1" Shut Off Valve X 3

## II. System Operation Parameter and Installation Checklist



**IMPORTANT!** The following condition for feed water supply must be met or warranty will be void and manufacturer assumes no responsibility for damage to system or property.

#### 1. Flow Direction

- Up Flow

#### 2. Water Temperature Parameter

- Maximum: 100° F (37.8° C)
- Minimum: 40° F (4.4° C)

#### 3. Water Pressure Parameter

\*Pressure reducer recommended if PSI exceeds 75 psi.

- Maximum: 75 PSI (5.98 kg/cm<sup>2</sup>)
- Minimum: 20 PSI (1.41 kg/cm<sup>2</sup>)

#### 4. pH Parameter

- Maximum: 9.5
- Minimum: 6.5

#### 5. Hardness Max

- 75 GPG (1338 PPM)

#### 6. Salinity Max

- 35000 PPM (mg/l)

#### 7. Iron Max

- 0.5 PPM (mg/l)

#### 8. Manganese Max

- 0.05 PPM (mg/l)

#### 9. Free Chlorine Max

- 3 PPM (mg/l)

#### 10. Copper Max

- 1.3 PPM (mg/l)

#### 11. Oil & Hydrogen Sulfide

- 0 PPM (mg/l)



**IMPORTANT!** A vacuum breaker may be needed for well water installation.

### Pre-Install Environment Checklist

- Do not use with water that is microbiologically unsafe or of unknown quality without adequate disinfection before or after the system.
- Do not install salt-free system in an area where it is exposed to direct sunlight and make sure the system is protected against freezing and extreme heat.
- \*To prevent water damage, high-flow pre-filter housing should be replaced every 4 years.

### III. Installation Safety Guide

- Handle with care when moving the water filtration system. Do not turn upside down, drop, drag, or set on areas with sharp protrusions.
- All of our media tanks have level adjusting tank bases. These tanks are designed to work with a “floating” base. This allows the tank to be leveled on any surface. Some applications may not have a level surface on which to place the tank. The floating base allows the tank to be leveled within the base and ensures proper operation. Sometimes the based can shift during shipping. It can be adjusted back by lifting the tank up no higher than 3” off the base , and letting it drop to help level the base.

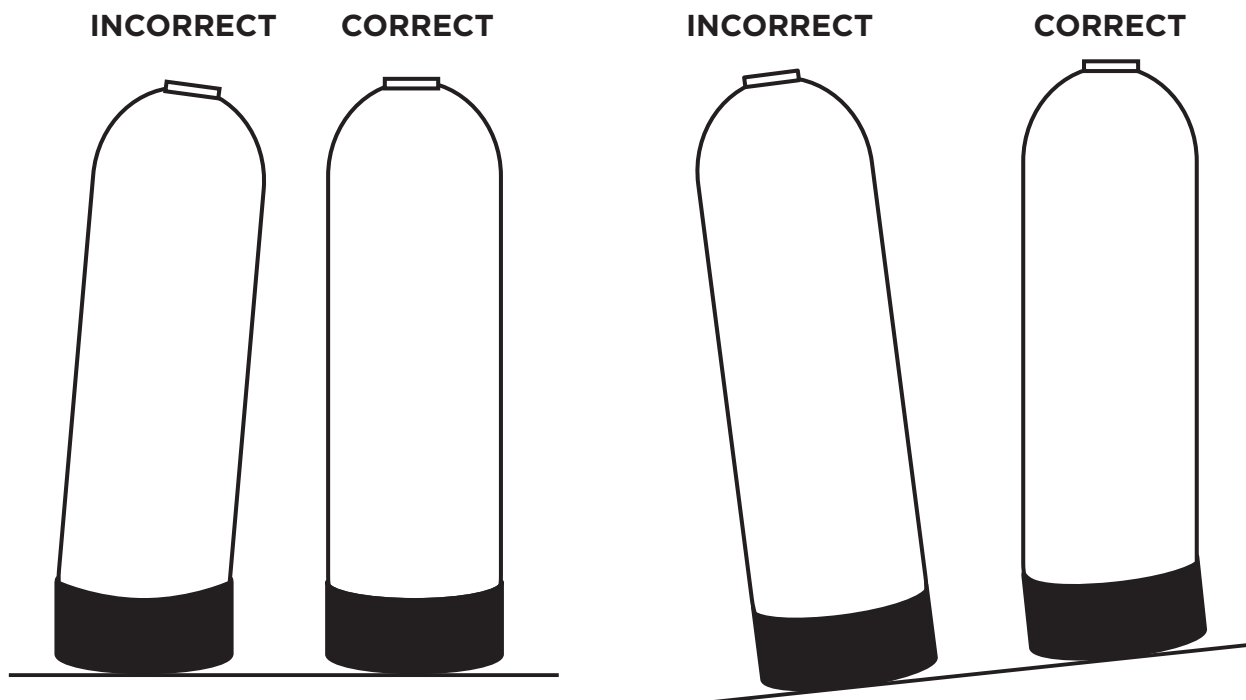

# INSTALLING THE SYSTEM

**IMPORTANT!** Locate and test the main water supply valve to the housing before installing the system. If the main water supply valve fails to shut off the water completely during the test, we recommend contacting your local plumber to fix the valve before begin installing the system.

**WARNING!** If this system is install in a metal (Conductive) plumbing system, i.e. copper or galvanized metal, the plastic components of the system will interrupt the continuity of the plumbing. As a result, any errant electricity from improperly grounded appliances or potential galvanic activity in the plumbing system can no longer ground through a contiguous metal system. Some older homes have been built in accordance with out-dated building codes, which actually encouraged the grounding of electrical appliances through plumbing. A grounded “**jumper wire**” bridging the equipment and reestablishing the contiguous conductive nature of the plumbing system must be installed prior to your system use.

**Note:** Although not required, we highly recommend installing a **bypass** before the system install to help ensure there’s no downtime for water usage during repairs or replacement of systems and filters.

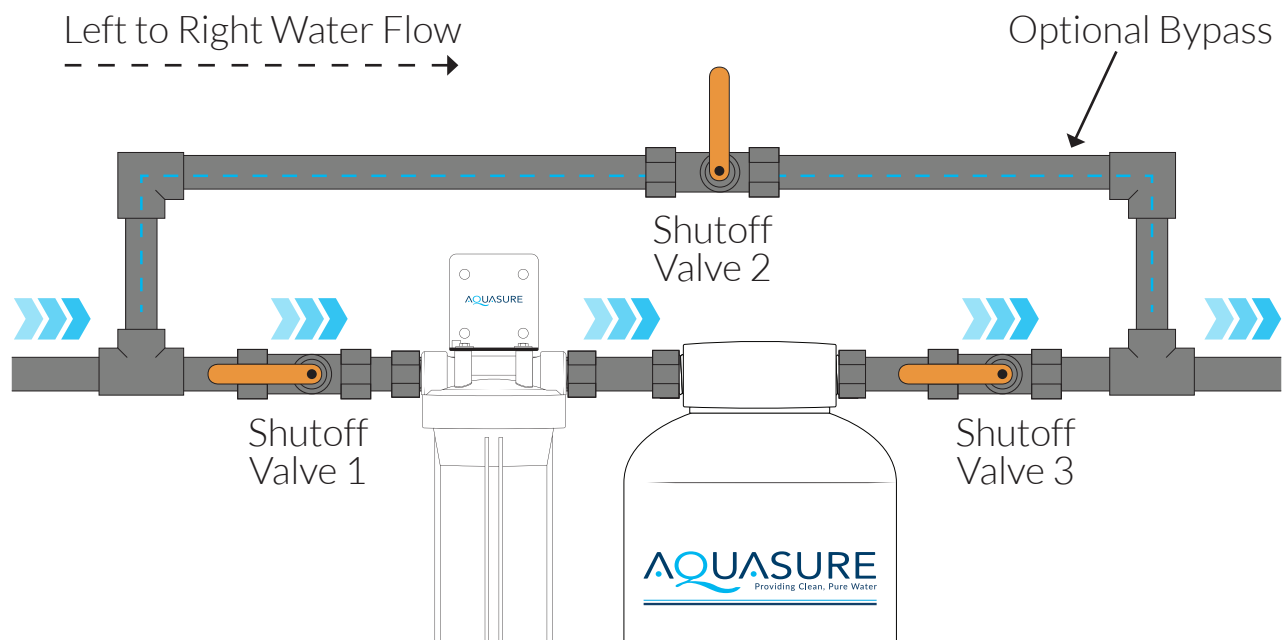

**IMPORTANT!** For maximum effectiveness and to lengthen the system life, the pre-filter system should always be placed before the treatment system.

### STEP 1. Checking the Direction of Water Flow

1. Inspect your water flow and determine if water is flowing from left to right or right to left.
2. If needed, reassemble the mounting bracket for the whole-house pre-filter if the direction is opposite of where the mounting bracket is facing.
3. Make sure the water flow will first be entering into the port opening indicated with an "IN" or directional arrow pointing inward and exits from the opening indicated with an "OUT" or directional arrow pointing outward.
4. Salt-Free System valve requires an up-flow setup. Follow **Step 7** of the installation for the correct flow connection.

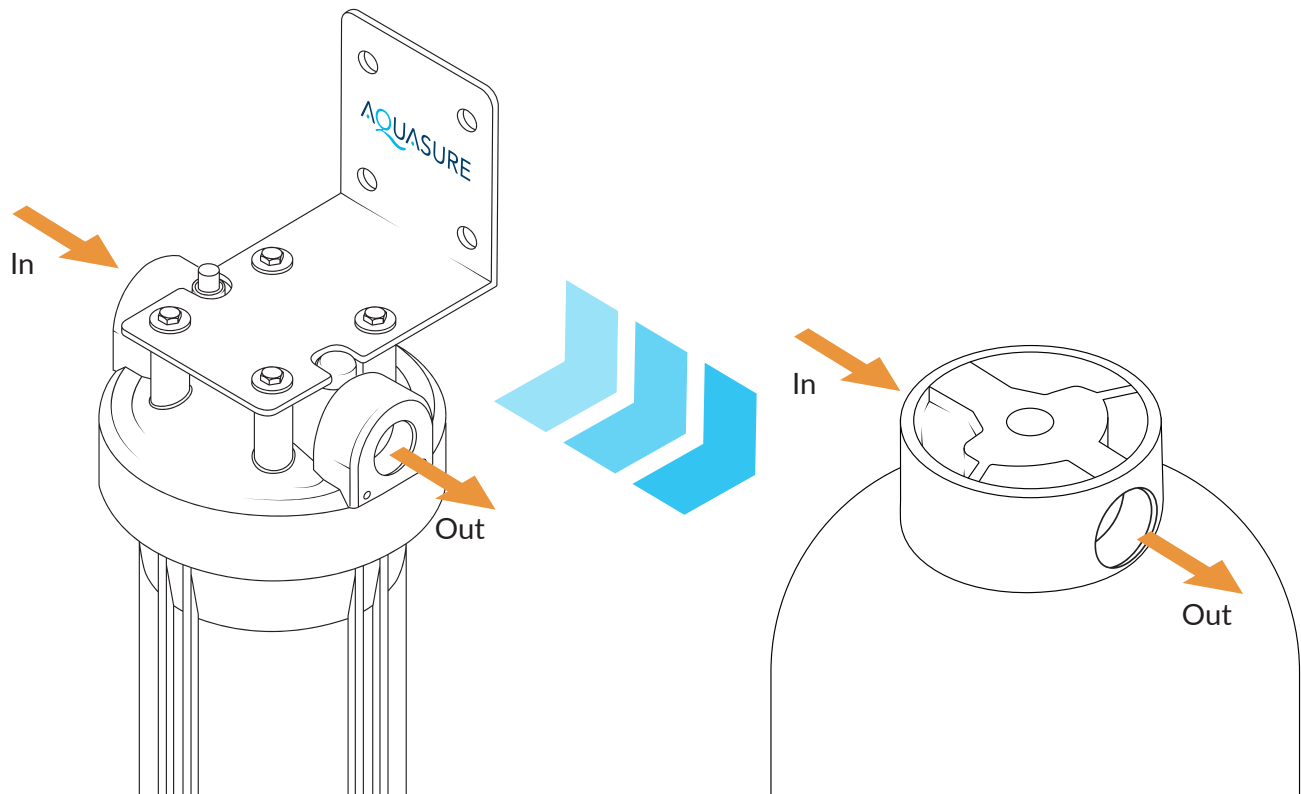

### STEP 2. Shutting Off the Main Water Supply Valve

1. Locate the main water supply valve of the house and turn it off completely.
2. Test to see if the water is completely shut off by turning on the faucet in the cold water position. If the cold water cannot be shut off, please contact your local plumber to fix the valve before begin installing the system.

### STEP 3. Mounting the Pre-Filter

1. Position the system on the wall at the desired mounting location with minimum of six (6) inches of ground clearance from the floor to the base of the system.
2. Using a pen or pencil and mark the mounting hole on the back of the bracket onto the wall.
3. **Note:** Please make sure the bracket mount is leveled using a leveling tool to ensure evenly distributed stress on the bracket. Make sure the mounting point is positioned on a stud to properly secure the bracket.
4. Mount the system onto the wall using the provided lag bolts and washers.

 **WARNING!** Pre-filters must be wall mounted to prevent stress on the plumbing.

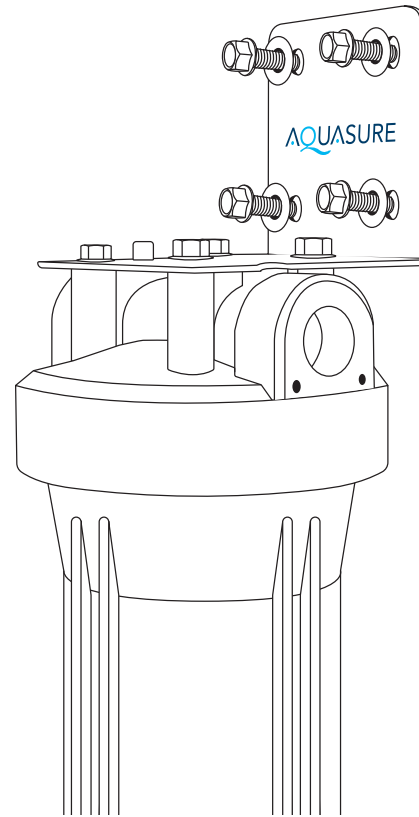

### STEP 4. Attaching the Water Supply Pipe to the Pre-Filter

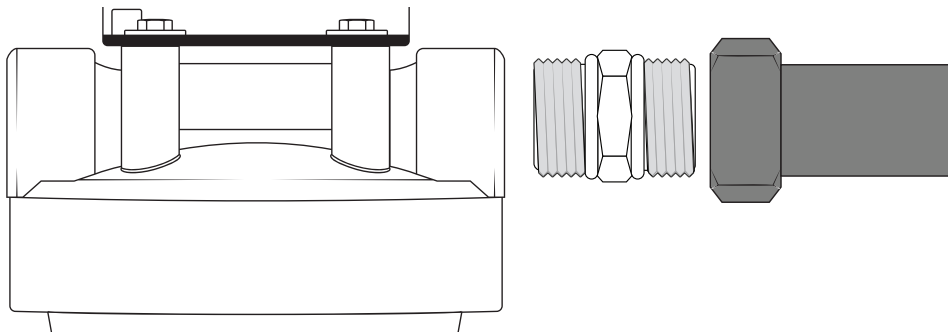

1. Wrap the 1" male threaded fittings that will be used to connect the plumbing to the pre-filter with five (5) to six (6) wraps of Teflon tape.
2. Attach the 1" male threaded fitting from the incoming water supply plumbing to the **IN** port and **OUT** port of the pre-filter system.
3. **Note:** Use the 1" to 3/4" inch male adapter for 3/4" plumbing.

### STEP 5. Installing the Pre-Filter Cartridge

1. Unwrap the filter cartridge and place it inside the housing. Make sure the filter is centered on the stand pipe located inside the housing at the base.
2. Screw on the housing with the filter inside and screw onto the corresponding head by turning it counterclockwise using the supplied housing wrench.
3. **Note:** Make sure the o-ring is inside the housing and do not over-tighten the housing.

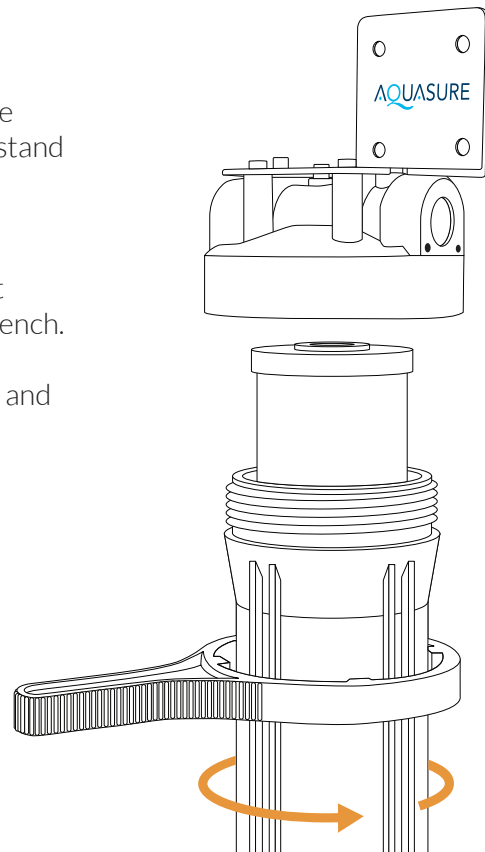

### STEP 6. Connecting the Plumbing onto the Valve

1. Follow the Diagram below and the arrow sticker on the head for a properly connected “upflow” setup required for the system to work correctly.
2. Wrap the 1” male threaded fittings that will be used to connect the plumbing with five (5) to six (6) wraps of Teflon tape.
3. Connect the plumbing by threading in the connection clockwise.

**Note:** If the water flow is reversed, damage to the system can occur.

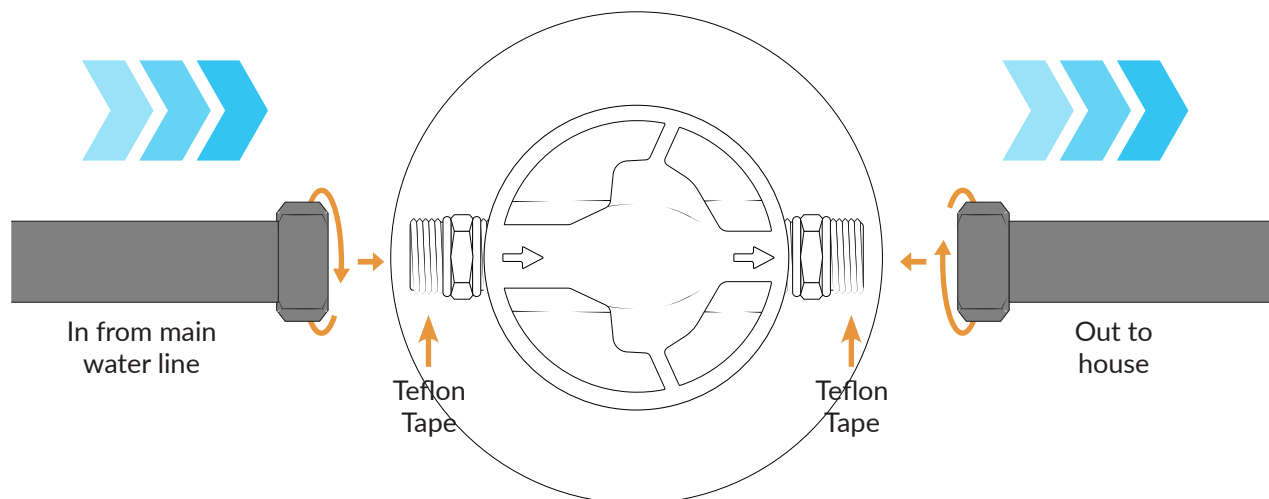

## STEP 7. System Startup



**WARNING!** Immediately shut off the main water supply valve if there are leaks. Check the leak area and see if there's a loose connection or if more Teflon tape is needed to prevent leaks from happening.

1. If bypass is installed, place the Salt-free system valve into bypass mode. If no bypass is installed you will need to turn off the water main to your home.
2. Find the nearest water faucet and remove the aerator or grid mesh on the faucet. Turn on the faucet before turning on the main water line to allow water to flow through.
3. Turn on the water from the main water supply and let it run for 10 minutes to release any trapped air bubbles or carbon media if a carbon filter is installed.
4. Check for Leaks!
5. After 10 mins, turn off the water from the nearest water faucet and reinstall the aerator or grid mesh back onto the faucet.

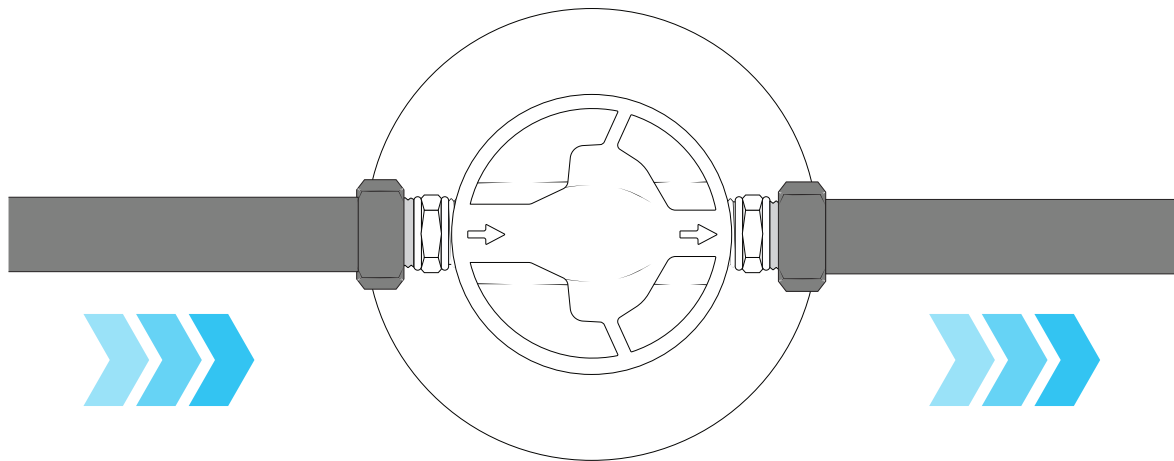

## CONGRATULATIONS!

Your system is ready to use. Please document the filter installation time and replace the filter in the suggested replacement time.

# THE ULTIMATE UPGRADE: ELEVATE YOUR WATER WITH OUR PREMIER SERIES REVERSE OSMOSIS SYSTEM

---

While the pre-filter and salt-free conditioner reduce various water contaminants, our RO system takes it a step further by removing up to 99% of impurities, providing refreshing, clean, and crisp-tasting drinking water.

- High-rejection membrane removes up to 99% of contaminants including arsenic, bacteria, chlorine, fluoride, heavy metals, lead, virus, and 1000s more.
- Clean drinking water is stored in a 3-gallon tank, ready whenever you are.
- The RO unit, holding tank, and drinking water faucet are all included in your purchase.
- Say goodbye to expensive bottled water. Our eco-friendly system helps you save money.



Scan and claim your exclusive  
**20% OFF** the Aquasure Reverse  
Osmosis Water Filter System



# SYSTEM MAINTENANCE

**Note:** It is recommend to change your whole-house pre-filter at least every 6-12 months for areas with bad water quality. Check your filter label for more details.



**IMPORTANT!** A label indicating the recommended duration of use before replacing the filter can be found on the included filter cartridge. This recommended time period should be considered starting from the point of first use.

## STEP 1. Shut off the Supply Water

**Note:** Before working on any system maintenance, get a clean cloth or microfiber towel to wipe off excess water that might spill during the filter replacement or system maintenance.

1. Turn the main water supply valve completely off.
2. Turn on the nearest faucet to release any excess water pressure built up inside the pipe.

## STEP 2. Remove the Filter Housing

1. Press the red pressure relief button on the top of the housing cap to relieve any pressure built up inside the system.
2. Use the housing wrench and turning it to the left to loosen.
3. Discard the old filter and clean the inside of housing and cap with warm water.

**Caution!** Do not use any chemical to wash the housing.

## STEP 3. Install the New Filter

1. Unwrap the filter and place it inside the housing, making sure the filter is centered on the stand pipe at the base of the housing.
2. Check the o-ring for cracks or damage. Replace o-ring if it is damaged.
3. Screw the housing with filter inside on to the head by turning it from left to right using the supplied housing wrench.
4. **Note:** Make sure the o-ring is seated in the housing. DO NOT over-tighten the housing.

## STEP 4. System Startup

1. Turn on the main water supply valve fully.
2. Check for leaks.
3. Turn on the nearest faucet and let the water run for 10 minutes to release any trapped air bubbles or carbon fines if a carbon filter is installed.
4. Shut off the water at the faucet.

# SUBSCRIBE AND SAVE

Never worry again when it's time to replace your filters.

Save time and money when replacing your Aquasure filter with our Subscribe and Save program!

Get 25% off your first order and then 10% off each subsequent order.

Signing up is easy...

1. Scan the QR code below OR go to [aquaresusa.com/subscribeandsave](https://aquaresusa.com/subscribeandsave).
2. Select your replacement filters.
3. Choose when you want to receive your new filters.

That's it!

Cancel or change your delivery frequency at any time.



Scan the QR code to order Aquasure certified replacement filters



# LIMITED PRODUCT WARRANTY

## Scope:

Aquasure takes pride in selling a superb line of products, including this whole house water filter ("Product"). As such, Aquasure expressly warrants to the original purchaser that, for a period of (5) years from the date of purchase if registered, or standard 1 year from the date of purchase if the system is not registered within 60 days of purchase, the product will be reasonably free of defects in materials and workmanship. Within the warranty covered period, Aquasure will, at its option, repair or replace the Product without charge, or refund the cost of the product, if the Product fails or does not perform as warranted solely due to a manufacturing defect within the warranty period, subject to the limitations and exclusions set forth in this Limited Product Warranty. This Limited Product warranty only applies when the Product is used, stored, handled, fabricated and/or installed in the manner recommended by Aquasure in the Installation Instruction & Owner's Manual ("Manual").

## Repair or Replacement:

Aquasure will replace any part and components within the warranty covered period from date of purchase, as indicated by the purchase order from authorized resellers or distributor, provided the failure is due to a defect in material or workmanship. The only exception shall be when proof of purchase or installation is provided and then the warranty period shall be from the date thereof. The stated warranty does not include labor charges necessary to repair or replace the defective product, nor does it include freight charges or any other local labor charges from third parties. The obligation to repair or replace shall further be limited to repair or replacement with the styles, models, products, colors, etc. of the Product that are available at the time of the repair or replacement, and shall be limited to the repair or replacement of only the specific Product that fails due to a manufacturing defect. Any repaired or replaced product shall also remain subject to the original warranty covered period from the date of the original purchase, and any repair or replacement shall not extend the original warranty period in any manner or start a new warranty period.

## Conditions of Validity of this Limited Product Warranty:

Even though the Product has extremely high endurance for operating conditions such as pH, maximum TDS, temperature, and optimum water pressure, THIS LIMITED PRODUCT WARRANTY SHALL ONLY BE VALID IF: The replaceable filters are changed and maintained on a regular basis as directed in the Manual. Moreover, depending on local water input water quality, regular maintenance may need to be increased.

## Non-Covered Defects:

THIS LIMITED PRODUCT WARRANTY DOES NOT COVER DEFECTS CAUSED BY:

1. Improper storage, installation, maintenance, handling, use and/or alterations of the Product, including, but not limited to, noncompliance with the installation, maintenance and standard operation conditions stated in the Manual and this Limited Product Warranty.
2. Unreasonable use, unintended use, or misuse of the Product for something other than its intended purpose as a whole house water filter.
3. Use of replacement parts, filters or other accessories that are not sold or manufactured by Aquasure for use with this particular Product.
4. Damage not resulting from manufacturing defects that occur while the Product is in the original purchaser's possession.
5. Installation of the Product with known or visible manufacturing defects at the time of installation.
6. Damage caused by freezing, flood, fire or Act of God.

### Conditions that render this limited product warranty void:

THIS LIMITED PRODUCT WARRANTY SHALL BE VOID IF:

1. The Product is not operated in compliance with normal municipal water conditions for which the particular model of this Product is intended.
2. The person seeking to invoke the warranty is not the original purchaser. That is, this Limited Product Warranty only extends to original purchasers.
3. The product is purchased used. That is, this Limited Product Warranty only covers new products.
4. The Product is purchased from someone other than Aquasure or one of Aquasure's authorized dealers. This is because, unless the Product was sold by Aquasure or one of its authorized dealers, Aquasure cannot verify or guarantee the integrity or authenticity of the Product.

### General Conditions

The warranties set forth herein are the only warranties made by Aquasure in connection with the product. Aquasure cannot and does not make any implied or express warranties with respect to the product, and disclaims all other warranties, including, but not limited to, any warranty of merchantability or fitness for a particular purpose. Products sold by Aquasure are sold only to the specifications specifically set forth by Aquasure in writing. Other than the limited product warranty set forth herein, Aquasure makes no other warranties, express or implied. Aquasure's sole obligation under this warranty shall be repair or replacement of a non-conforming product or parts of the product, or at the option of Aquasure, return of the product and a refund of the purchase price. Buyer assumes all risk whatsoever as to the result of the use of the product purchased, whether used singularly or in combination with any other products or substances.

No claim by the buyer/owner of any kind, including claims for indemnification, shall be greater in amount than the purchase price of the products in respect to which damages are claimed. In no event shall Aquasure be liable to buyer/owner in tort, contract or otherwise, for any special, indirect, incidental, consequential, reliance, statutory, special, punitive or exemplary damages, including, but not limited to, lost profits, loss of use, loss of time, inconvenience, damage to goodwill or reputation, or loss of data, even if advised of the possibility of such damages or such damages could have been reasonably foreseen, in connection with, arising out of, or as a result of, the sale, delivery, servicing, use or loss of use of the products sold hereunder, or for any liability of buyer to any third party with respect thereto.

### Obtaining Warranty Coverage or General Inquiries

If coverage is available, you may obtain coverage under this Limited Product Warranty by providing Aquasure with proof of original purchase, and that you are the original purchaser. For service under this Limited Product Warranty, you must notify Aquasure by phone at 1-800-661-0680, by email at support@aquasureusa.com, or in writing at 5015 Hallmark Parkway, San Bernardino, CA 92407. In making the claim, please provide your name, address, phone number, a description of the product involved, and an explanation of the defect.



[www.AquasureUSA.com](http://www.AquasureUSA.com) | 800.661.0680 | [support@aquasureusa.com](mailto:support@aquasureusa.com)