

AQUASURE

FORTITUDE PRO SERIES
WHOLE HOUSE WATER TREATMENT SYSTEM



⚠ IMPORTANT!
For optimum performance and protection against contaminants, please fully read this owner's manual before proceeding with installation.

TABLE OF CONTENT

<u>WELCOME & CONGRATULATIONS</u>	<u>1</u>
<u>EXTENDED WARRANTY REGISTRATION</u>	<u>2</u>
<u>INSPECTION & PREPARATION</u>	<u>3</u>
I. Be familiar with the system before installation	
II. System Operation Parameter and Installation checklist	
III. Installation Safety Guide	
<u>INSTALLING THE SYSTEM</u>	<u>6</u>
STEP 1. Checking the Direction of Main Water Flow	
STEP 2. Shutting Off the Main Water Supply Valve	
STEP 3. Mounting the Pre-Filter	
STEP 4. Attaching the Water Supply to the Pre-Filter	
STEP 5. Installing the Pre-Filter Cartridge	
STEP 6. Attaching the Water Supply Pipe to the System	
STEP 7. Mounting the Valve Body onto the Media Tank	
STEP 8. Connecting the Plumbing onto the Valve	
STEP 9. System Startup	
<u>GETTING TO KNOW THE VALVE HEAD</u>	<u>12</u>
<u>SYSTEM MAINTENANCE</u>	<u>13</u>
STEP 1. Shutting Off the Supply Water	
STEP 2. Removing the Filter Housing	
STEP 3. Install the New Filter	
STEP 4. System Startup	
<u>REPLACE YOUR PRE-FILTER</u>	<u>14</u>
<u>LIMITED PRODUCT WARRANTY</u>	<u>15</u>

WELCOME & CONGRATULATIONS

Thank you for choosing Aquasure. This owner's manual will guide you through the necessary steps to fully self-install the Fortitude Pro Series Whole House Water Filter System.

For MAXIMUM effectiveness please thoroughly read this manual.

This owner's manual serves as a source of general guidance; nevertheless, it is crucial to emphasize that errors during installation may result in system malfunction and can potentially void the warranty. Therefore, it is strongly recommended to engage the services of a licensed plumber for professional installation. The information listed in this manual covers the steps for a self-serve installation. In the event that you need support, our Aquasure technicians are available to answer any questions during hours of operation as listed below.

Hours of Operation: M-F 8:30AM - 5:30PM PST

Telephone: (800) 661-0680

Email: support@aquasureusa.com

Online Chat: aquasureusa.com/support

DON'T MISS OUT ON FOUR FREE YEARS WITH AQUASURE EXTENDED WARRANTY

Register your product within 60 Days from time of purchase to keep your full 5 year warranty. Simply visit aquasureusa.com/support and enter your purchase and serial number. Or fill out the information below and follow the steps.

Fill in the information below for future reference and submit using the instructions below to receive the extended 4 year product warranty..

Purchaser Name: _____

Email: _____

Phone: _____

Address: _____

City: _____

State: _____

Zip: _____

Order Number: _____

Order Date: _____

Serial Number: _____

Place of Order: _____

Registration with your mobile device is easy.

1. Fill out the form by handwriting your info.
2. Take a picture of the form with your device.
3. Scan the QR code with your device camera and click the banner that appears.
4. Attach the picture of the form to the email that opens.
5. Hit Send and you're DONE!



Where to find your Serial Number



INSPECTION & PREPARATION

I. Be Familiar with the System Before Installation

i **IMPORTANT!** Please read the entire manual and become familiar with instructions and parts needed before proceeding with the installation.

Inspect the System

Please take the system and all the components out of the box. Inspect the system and all the connection fittings carefully, make sure nothing is damaged during shipping. If any part is cracked or broken, please do not proceed with the installation and contact Aquasure or your distributor for an exchange or diagnosis.

System components breakdown for Fortitude PRO Whole House Water Treatment System

Pleated Sediment Pre-Filter

Parts:

- Aquasure High Flow Housing
- Aquasure Pleated Sediment Filter
- Aquasure Housing Wrench
- Aquasure Housing Mounting Bracket
- Mounting Bolts x 8
- Washers x 8
- Nipple 1" to 1" x 2
- Nipple 1" to 3/4" x 2

Pro Grade Mix Media Water Treatment System

Parts:

- Aquasure High Strength Fiberglass Tank
- Aquasure MFV Valve Head with 1" in/out Ports and Media Reset Backwash Port
- Media (Prefilled)
- Nipple 1" to 1" x 3
- Nipple 1" to 3/4" x 3
- Valve Head O-Ring
- In/Out Port O-Rings x 3



* 10" Pleated sediment filter is shown here. Pre-filter size may vary depending on the system configuration

Recommended Tool List for System Installation

- Variable Speed Drill
- Drill Bit
- Bolt Bit
- Adjustment Wrench
- Level Tool
- Teflon Tape
- Pen or Pencil

Recommended Parts List for System Installation

- 1" Male Thread Adapter X 4
- 1" Shut Off Valve X 3

II. System Operation Parameter and Installation checklist



IMPORTANT! The following condition for feed water supply must be met or warranty will be void and manufacturer assumes no responsibility for damage to system or property.

1. Water Temperature Parameter

- Maximum: 100° F (37.8° C)
- Minimum: 40° F (4.4° C)

2. Water Pressure Parameter

*Pressure reducer recommended if PSI exceeds 75 psi.

- Maximum: 75 PSI (5.98 kg/cm²)
- Minimum: 20 PSI (1.41 kg/cm²)

3. pH Parameter

- Maximum: 10
- Minimum: 5

* A vacuum breaker may be needed for well water installation.

4. Pre-install environment checklist

- Do not use with water that is microbiologically unsafe or of unknown quality without adequate disinfection before or after the system.
- Filtration system must not be installed at an area where it is exposed to direct sunlight and must be protected against freezing and extreme heat.
- To prevent possible water damage, high flow housing should be replaced every 4 years.

III. Installation Safety Guide

- Handle with care when moving the water filtration system. Do not turn upside down, drop, drag, or set on areas with sharp protrusions.
- All of our media tanks have level adjusting tank bases. These tanks are designed to work with a “floating” base. This allows the tank to be leveled on any surface. Some applications may not have level surface to place the tank. The floating base allows the tank to be leveled within the base and ensure proper operation. Sometimes the based can shift during shipping. It can be adjusted back by lifting the tank up no higher than 3” off the base , and letting it drop to help level the base.

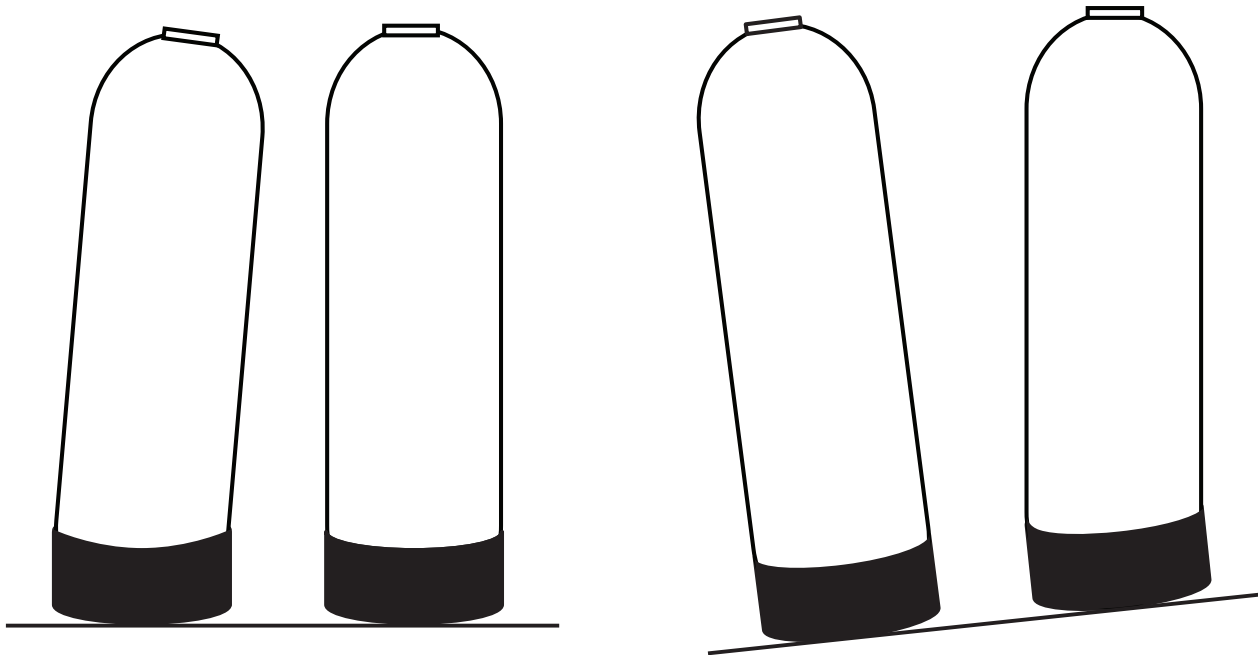

INSTALLING THE SYSTEM

IMPORTANT! Locate and test the main water supply valve to the housing before installing the system. If the main water supply valve fails to shut off the water completely during the test, we recommend contacting your local plumber to fix the valve before begin installing the system.

WARNING! If this system is install in a metal (Conductive) plumbing system, i.c. copper or galvanized metal, the plastic components of the system will interrupt the continuity of the plumbing system. As a result, any arrant electricity from improperly grounded appliances downstream or potential galvanic activity in the plumbing system can no longer ground through contiguous metal plumbing. Some homes may have been built in accordance with building codes, which actually encouraged the grounding of electrical appliances through plumbing. A grounded “jumper wire” bridging the equipment and reestablishing the contiguous conductive nature of the plumbing system must be installed prior to your system use.

Note: Although not required, we highly recommend installing a bypass before the system install to help ensure there’s no downtime for water usage during repairs or replacement of systems. See **Diagram A** for bypass installation examples.

Note: Depending on the water flow direction, the media reset backwash port may be located in the front or the rear of the system. See **Diagram B** for port direction examples.

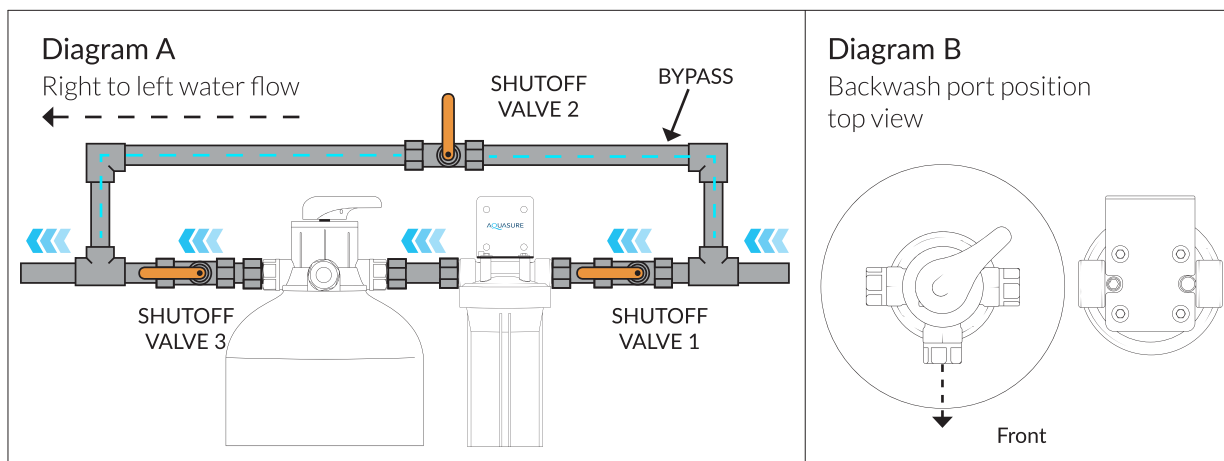
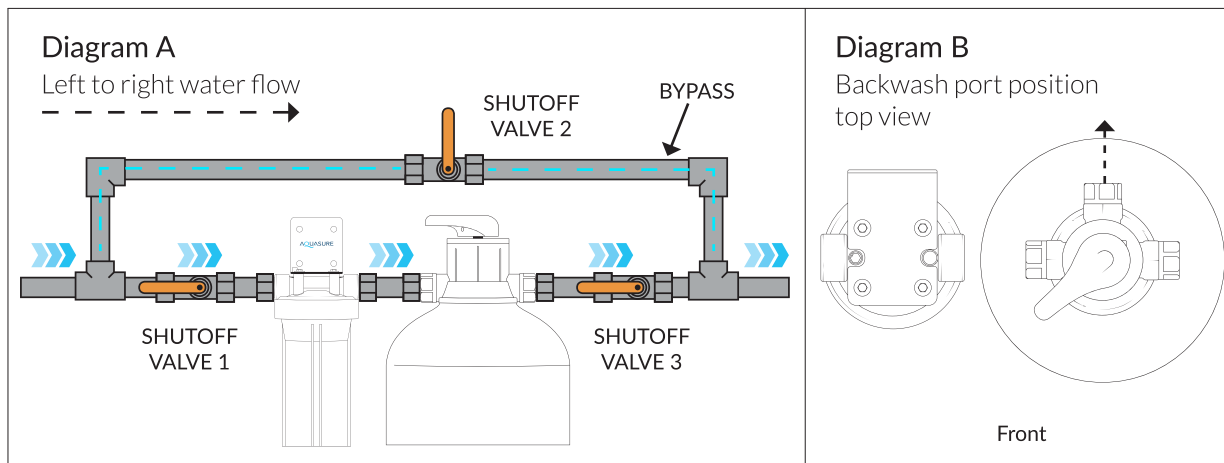

IMPORTANT! For maximum effectiveness and to lengthen the system life the pre-filter system should always be placed before the treatment system.

STEP 1. Checking the Direction of Water Flow

1. Inspect your water flow and determine if water is flowing from left to right or right to left.
2. If needed, reassemble the mounting bracket for the pleated sediment filter if the direction is opposite of where the mounting bracket is facing.
3. Make sure the water flow will first be entering into the port opening indicated with an "IN" or directional arrow pointing inward and exits from the opening indicated with an "OUT" or directional arrow pointing outward.

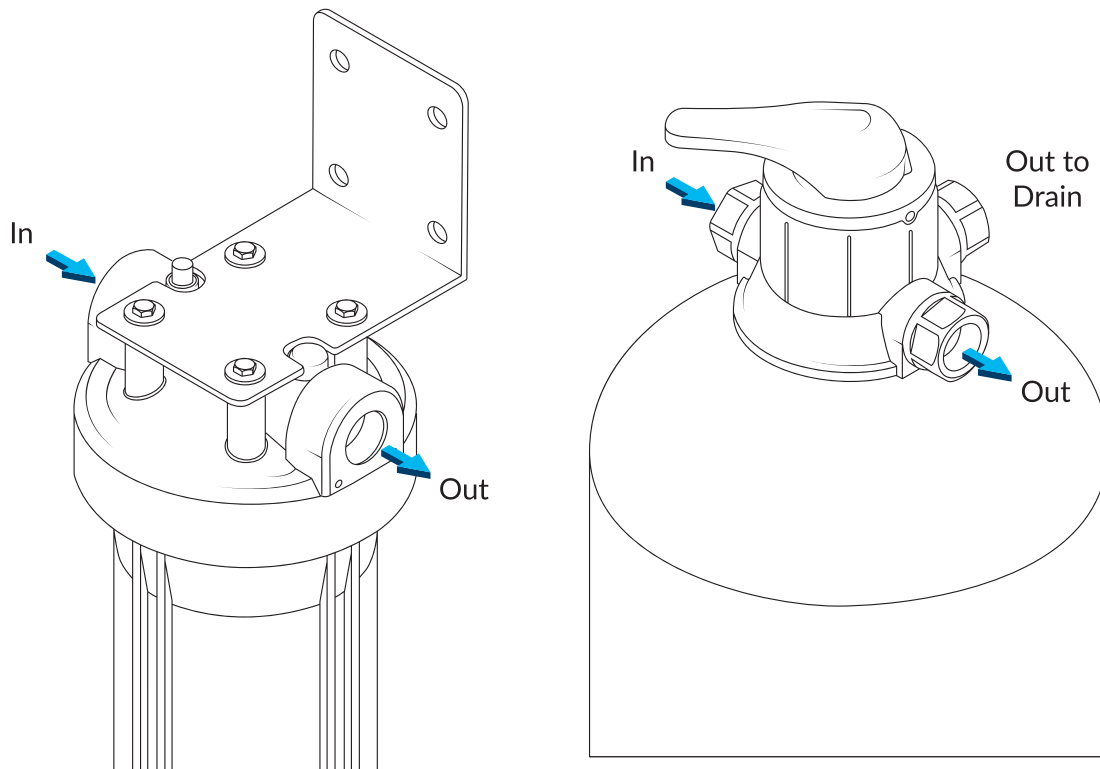

STEP 2. Shutting Off the Main Water Supply Valve

1. Locate the main water supply valve of the house and turn it off completely by turning the shut-off handle clockwise.
2. Test to see if the water is completely shut off by turning on the faucet in the cold water position. If the cold water cannot be shut off, please contact your local plumber to fix the valve before begin installing the system.

STEP 3. Mounting the Pre-Filter

1. Position the system on the wall at the desired mounting location with minimum of six (6) inches of ground clearance from the floor to the base of the system.
2. Using a pen or pencil and mark the mounting hole on the back of the bracket onto the wall.

Note: Please make sure the bracket mount is leveled using a leveling tool to ensure evenly distributed stress on the bracket. Make sure the mounting point is position on a stud to properly secure the bracket.

3. Mount the system onto the wall using the provided Lag Bolts and Washers.

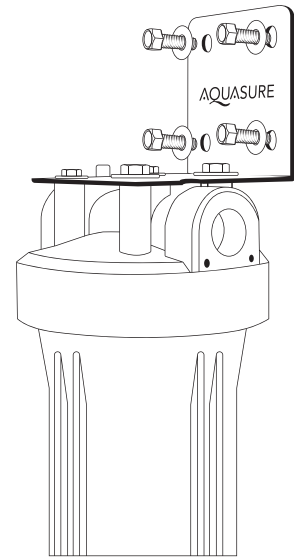

STEP 4. Attaching the Water Supply Pipe to the Pre-Filter

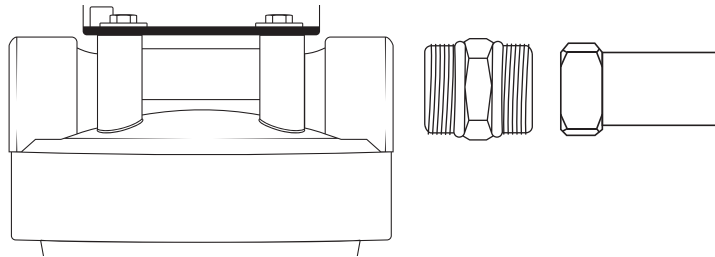

1. Wrap the 1" male threaded fittings that will be used to connect the plumbing to the pre-filter with five (5) to six (6) wraps of Teflon tape.
2. Attach the 1" male threaded fitting from the incoming water supply plumbing to the **IN** port and **OUT** port of the pre-filter system.

Note: Use the 1" to 3/4" inch male adapter for 3/4" plumbing

STEP 5. Installing the Pre-Filter Cartridge

1. Unwrap the filter cartridge and place it inside the housing. Make sure the filter is centered on the stand pipe located inside the housing at the base.
2. Screw on the housing with the filter inside and screw onto the corresponding head by turning it counterclockwise using the supplied housing wrench.

Note: Make sure the o-ring is inside the housing and do not over tightening the housing.

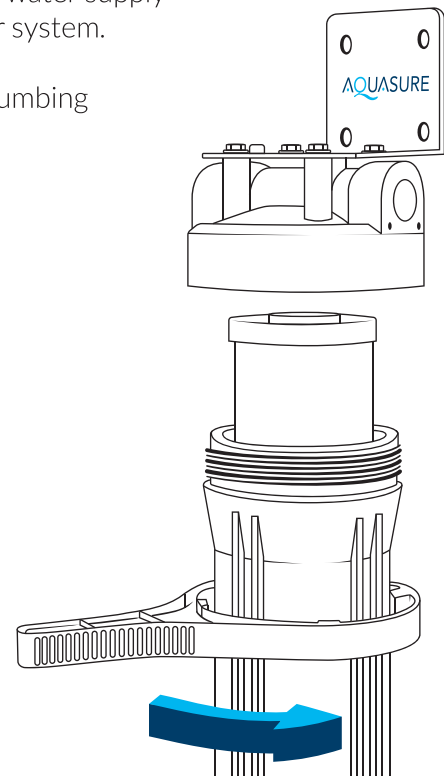

STEP 6. Attaching the Water Supply Pipe to the Treatment System

Place the blue gasket in between the valve body and the adapter. Screw the adapter into the valve body.

Apply the same procedure to all three openings.

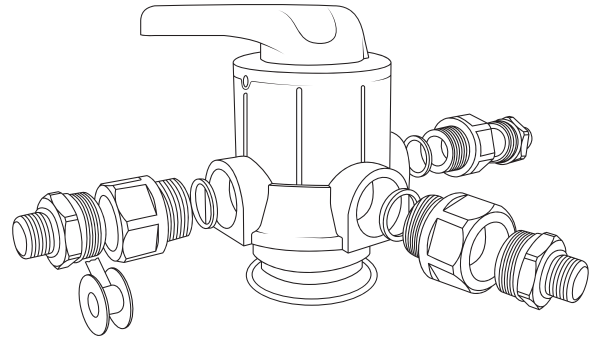

Note: Make sure the o-ring is inside the housing and do not over tightening the housing.

STEP 7. Mounting the Valve Body onto the Media Tank

1. Apply a small amount of lubricant onto the o-ring of the valve body. (Do not apply lubricant on the thread.)

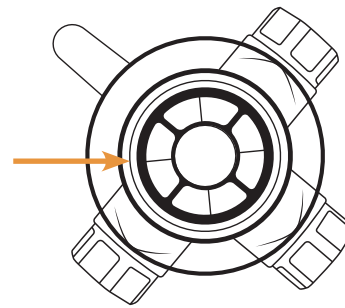

2. Lubricate the riser tube located on the opening of the media tank. Make sure the riser tube is flush with the top of the tank.

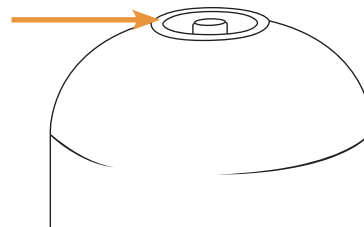

3. Install the upper basket on the bottom of the valve by lining up the tabs, pressing in, then turning the basket counterclockwise to lock it in place.

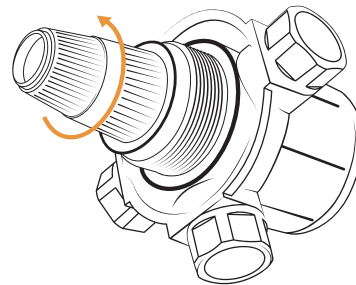

STEP 7 (Continued...). Mounting the Valve Body onto the Media Tank

1. Place the upper basket over the riser tube and push the valve on the tank. Thread the valve on the tank by turning clockwise. Be sure not to cross-thread the valve.

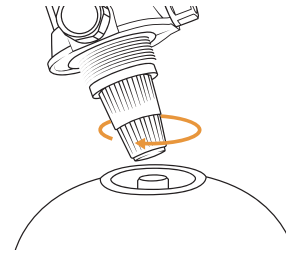

2. Tighten the valve hand tight, then snug it further by tapping it with the palm of the hand. Do not use tools to tighten the valve or damage could occur.

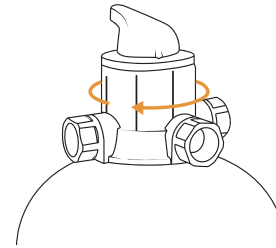

STEP 8. Connecting the Plumbing onto the Valve

1. Follow the diagram and arrows on the valve to make sure the path of the water is properly connected.

Note: If the water flow is reversed, damage to the system can occur.

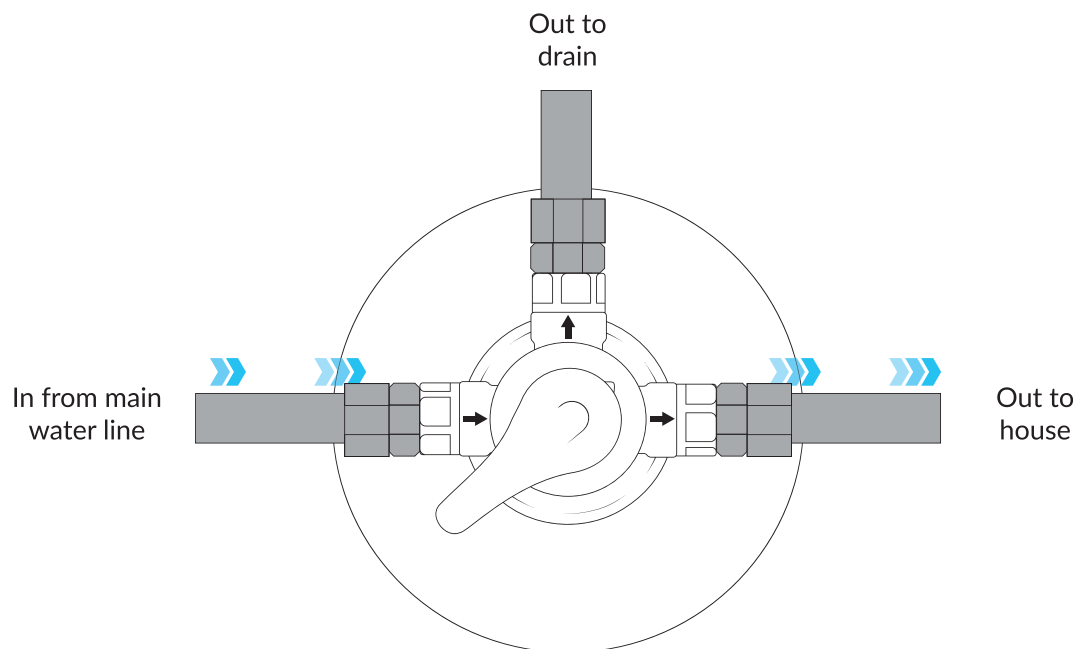

STEP 9. System Startup



WARNING! Immediately shut off the main water supply valve if there are leaks. Check the leak area and see if there's a loose connection or if more Teflon tape is needed to prevent leaks from happening.

1. Find the nearest water faucet and remove the aerator or grid mesh on the faucet. Turn on the faucet before turning on the main water line to allow water to flow through.
2. **Place the Fortitude Pro Series on Fast Rinse** setting.
3. Turn on the water and let it run for 10 minutes to release any trapped air bubbles or carbon media if a carbon filter is installed.
4. Check for leaks!
5. After 10 mins, turn off the water from the nearest water faucet and reinstall the aerator or grid mesh back onto the faucet.

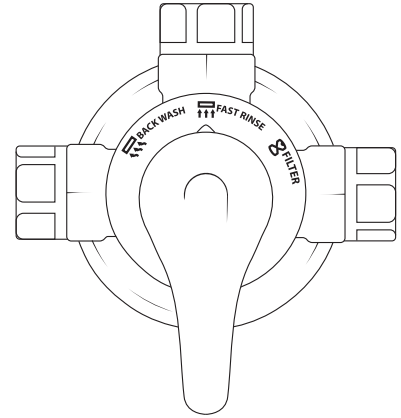



CONGRATULATIONS!

Your system is ready to use. Please document the filter installation time and replace the filter in the suggested replacement time.

GETTING TO KNOW THE VALVE HEAD

i IMPORTANT! The valve head has three settings. By reviewing the information below you can ensure the system is working properly and providing you with improved water quality.

Process	Description	Recommended Time
FILTER 	<p>This is the standard setting when your water treatment system is in use.</p> <p>Water will flow in from the source and out to your home plumbing.</p>	Ongoing
BACKWASH 	<p>The Backwash setting is used to remove impurities from the system and expands the media.</p> <p>Water will flow out of the valve port that should be sent to the drain.</p>	<p>Recommend every 7-10 days or as needed.</p> <p>Run water for 15 minutes. Then perform a Fast Rinse cycle.</p> <p>More time may be needed if desired result is not achieved.</p>
FAST RINSE 	<p>Fast Rinse setting is used immediately after the Backwash cycle. The Fast Rinse process forces the media to settle back down into the tank.</p> <p>Water will flow out of the valve port that should be sent to the drain.</p>	<p>Perform immediately after the Backwash cycle.</p> <p>Run water for 5 minutes.</p>

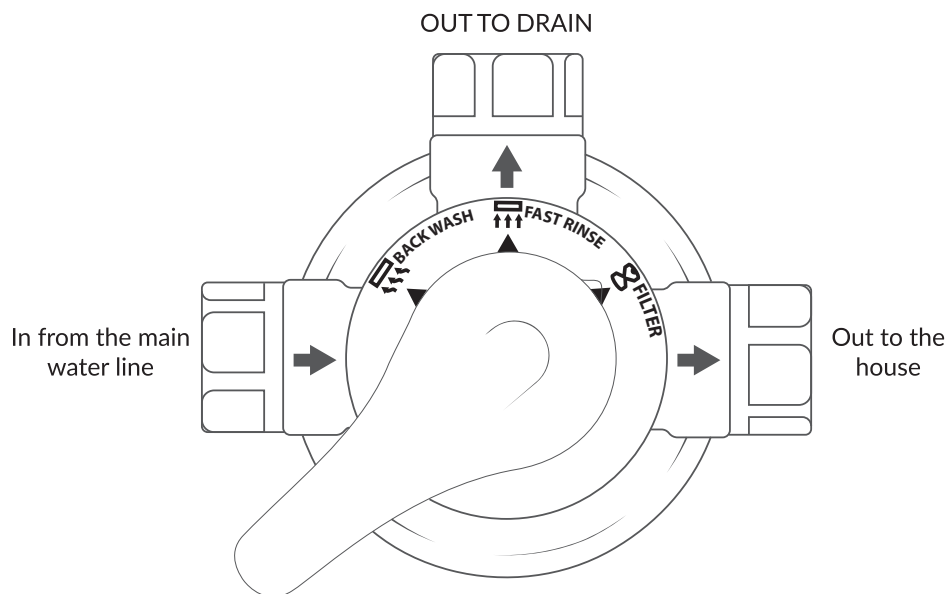

SYSTEM MAINTENANCE

Note: It is recommend to change your Stage 1 pre-filter at least every 4 - 6 month for areas with bad water quality. Check your filter label for more details.

Note: It is recommend to perform a backwash cycle for 15 minutes and fast rinse cycle for 5 minutes at least once a week.



IMPORTANT! A label can be found on the included filter cartridge. This label indicates the recommended duration of use before replacing the filter. This recommended time period should be considered starting from the point of first use.

STEP 1. Shutting off the Supply Water

Caution! Before working on any system maintenance, get a clean cloth or microfiber towel to wipe off excess water that might spill during the filter replacement or system maintenance.

1. Turn the main water supply valve completely off by rotating it clockwise.
2. Turn on the nearest faucet to release any excess water and pressure that is built up inside the pipe.

STEP 2. Removing the Filter Housing

1. Press the red pressure relief button on the top of the housing cap to relief any pressure built up inside the system.
2. Using the housing wrench and turning it to the left to loosen
3. Discard the old filter and clean the inside of housing and cap with warm water.

Caution! Do not use any chemical to wash the housing.

STEP 3. Install the New Filter

1. Unwrapped the filter and place it inside the housing and make sure the housing is centered on the stand pipe located inside the housing at the base.
2. Check the o-ring for cracks or damage. Replace o-ring if it is damaged.
3. Screw on the housing with filter inside to the corresponding head by turning it from left to right using the supplied housing wrench.

Note: Make sure the o-ring is inside the housing and do not over tightening the housing.

STEP 4. System Startup

1. Turn on the main water supply valve fully by turning it counterclockwise
2. Check for leaks
3. Turn on the nearest faucet and let the water run for 10 minutes to release any trapped air bubble or carbon fine if a carbon filter is installed.

SUBSCRIBE AND SAVE

Never worry again when it's time to replace your filters.

Save time and money when replacing your Aquasure Pleated Sediment Filter with our Subscribe and Save program!

Get 25% off your first order and then 10% each order after that.

Signing up is easy...

1. Scan the QR code below OR go to aquasureusa.com/subscribeandsave
2. Select your replacement filters
3. Choose when you want to receive your new filters

That's it!

Cancel or change your delivery frequency at any time.

Scan the QR code to
order Aquasure certified
replacement filters



LIMITED PRODUCT WARRANTY

Scope:

Aquasure takes pride in selling a superb line of products, including this whole house water filter ("Product"). As such, Aquasure expressly warrants to the original purchaser that, for a period of (5) years from the date of purchase if registered, or standard 1 year from the date of purchase if the system is not registered within 60 days of purchase, the product will be reasonably free of defects in materials and workmanship. Within the warranty covered period, Aquasure will, at its option, repair or replace the Product without charge, or refund the cost of the product, if the Product fails or does not perform as warranted solely due to a manufacturing defect within the warranty period, subject to the limitations and exclusions set forth in this Limited Product Warranty. This Limited Product warranty only applies when the Product is used, stored, handled, fabricated and/or installed in the manner recommended by Aquasure in the Installation Instruction & Owner's Manual ("Manual").

Repair or Replacement:

Aquasure will replace any part and components within the warranty covered period from date of purchase, as indicated by the purchase order from authorized resellers or distributor, provided the failure is due to a defect in material or workmanship. The only exception shall be when proof of purchase or installation is provided and then the warranty period shall be from the date thereof. The stated warranty does not include labor charges necessary to repair or replace the defective product, nor does it include freight charges or any other local labor charges from third parties. The obligation to repair or replace shall further be limited to repair or replacement with the styles, models, products, colors, etc. of the Product that are available at the time of the repair or replacement, and shall be limited to the repair or replacement of only the specific Product that fails due to a manufacturing defect. Any repaired or replaced product shall also remain subject to the original warranty covered period from the date of the original purchase, and any repair or replacement shall not extend the original warranty period in any manner or start a new warranty period.

Conditions of Validity of this Limited Product Warranty:

Even though the Product has extremely high endurance for operating conditions such as pH, maximum TDS, temperature, and optimum water pressure, THIS LIMITED PRODUCT WARRANTY SHALL ONLY BE VALID IF: The replaceable filters are changed and maintained on a regular basis as directed in the Manual. Moreover, depending on local water input water quality, regular maintenance may need to be increased.

Non-Covered Defects:

THIS LIMITED PRODUCT WARRANTY DOES NOT COVER DEFECTS CAUSED BY:

1. Improper storage, installation, maintenance, handling, use and/or alterations of the Product, including, but not limited to, noncompliance with the installation, maintenance and standard operation conditions stated in the Manual and this Limited Product Warranty.
2. Unreasonable use, unintended use, or misuse of the Product for something other than its intended purpose as a whole house water filter.
3. Use of replacement parts, filters or other accessories that are not sold or manufactured by Aquasure for use with this particular Product.
4. Damage not resulting from manufacturing defects that occur while the Product is in the original purchaser's possession.
5. Installation of the Product with known or visible manufacturing defects at the time of installation.
6. Damage caused by freezing, flood, fire or Act of God.

Conditions that render this limited product warranty void:

THIS LIMITED PRODUCT WARRANTY SHALL BE VOID IF:

1. The Product is not operated in compliance with normal municipal water conditions for which the particular model of this Product is intended.
2. The person seeking to invoke the warranty is not the original purchaser. That is, this Limited Product Warranty only extends to original purchasers.
3. The product is purchased used. That is, this Limited Product Warranty only covers new products.
4. The Product is purchased from someone other than Aquasure or one of Aquasure's authorized dealers. This is because, unless the Product was sold by Aquasure or one of its authorized dealers, Aquasure cannot verify or guarantee the integrity or authenticity of the Product.

General Conditions

The warranties set forth herein are the only warranties made by Aquasure in connection with the product. Aquasure cannot and does not make any implied or express warranties with respect to the product, and disclaims all other warranties, including, but not limited to, any warranty of merchantability or fitness for a particular purpose. Products sold by Aquasure are sold only to the specifications specifically set forth by Aquasure in writing. Other than the limited product warranty set forth herein, Aquasure makes no other warranties, express or implied. Aquasure's sole obligation under this warranty shall be repair or replacement of a non-conforming product or parts of the product, or at the option of Aquasure, return of the product and a refund of the purchase price. Buyer assumes all risk whatsoever as to the result of the use of the product purchased, whether used singularly or in combination with any other products or substances.

No claim by the buyer/owner of any kind, including claims for indemnification, shall be greater in amount than the purchase price of the products in respect to which damages are claimed. In no event shall Aquasure be liable to buyer/owner in tort, contract or otherwise, for any special, indirect, incidental, consequential, reliance, statutory, special, punitive or exemplary damages, including, but not limited to, lost profits, loss of use, loss of time, inconvenience, damage to goodwill or reputation, or loss of data, even if advised of the possibility of such damages or such damages could have been reasonably foreseen, in connection with, arising out of, or as a result of, the sale, delivery, servicing, use or loss of use of the products sold hereunder, or for any liability of buyer to any third party with respect thereto.

Obtaining Warranty Coverage or General Inquiries

If coverage is available, you may obtain coverage under this Limited Product Warranty by providing Aquasure with proof of original purchase, and that you are the original purchaser. For service under this Limited Product Warranty, you must notify Aquasure by phone at 1-800-661-0680, by email at support@aquasureusa.com, or in writing at 12403 Central Ave., Chino, CA 91710-2604. In making the claim, please provide your name, address, phone number, a description of the product involved, and an explanation of the defect.

AQUASURE

www.AquasureUSA.com | 800.661.0680 | support@aquasureusa.com